

**LEGO**

# SPACE POLICE

5982



1

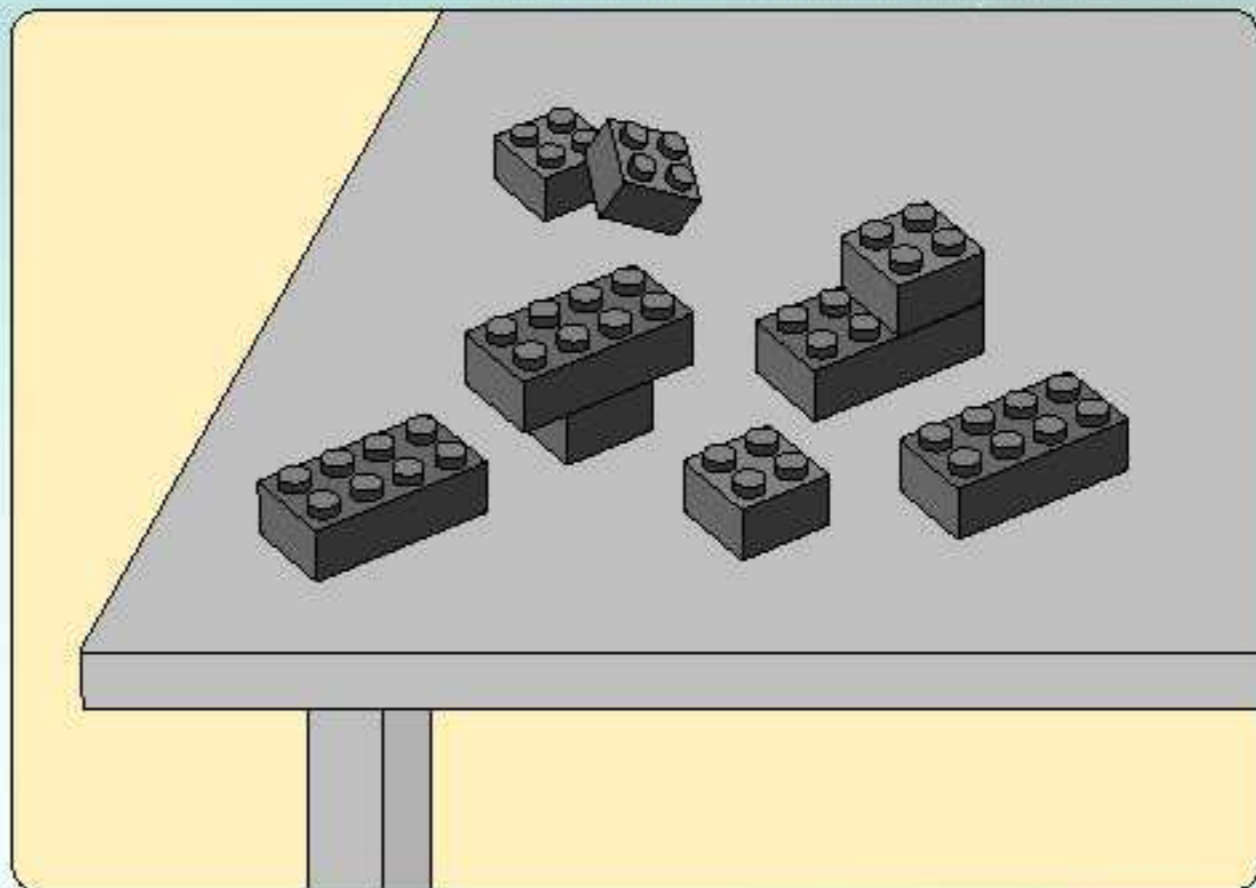
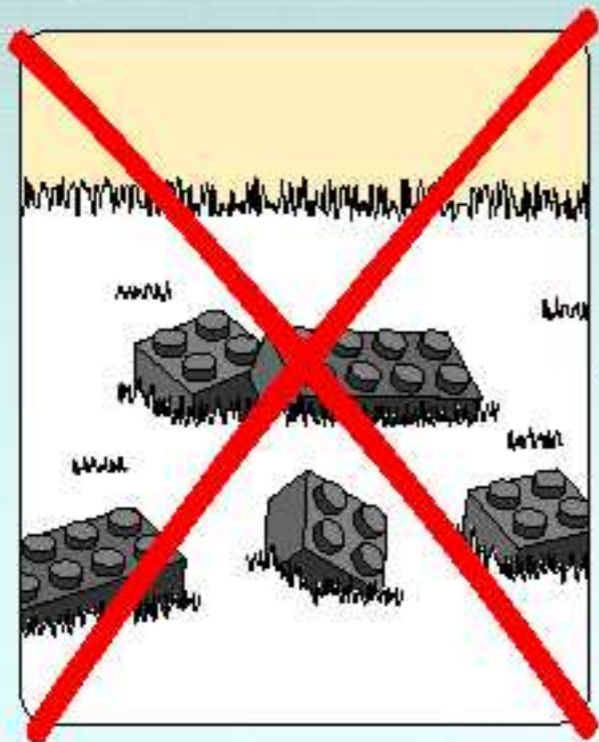

2

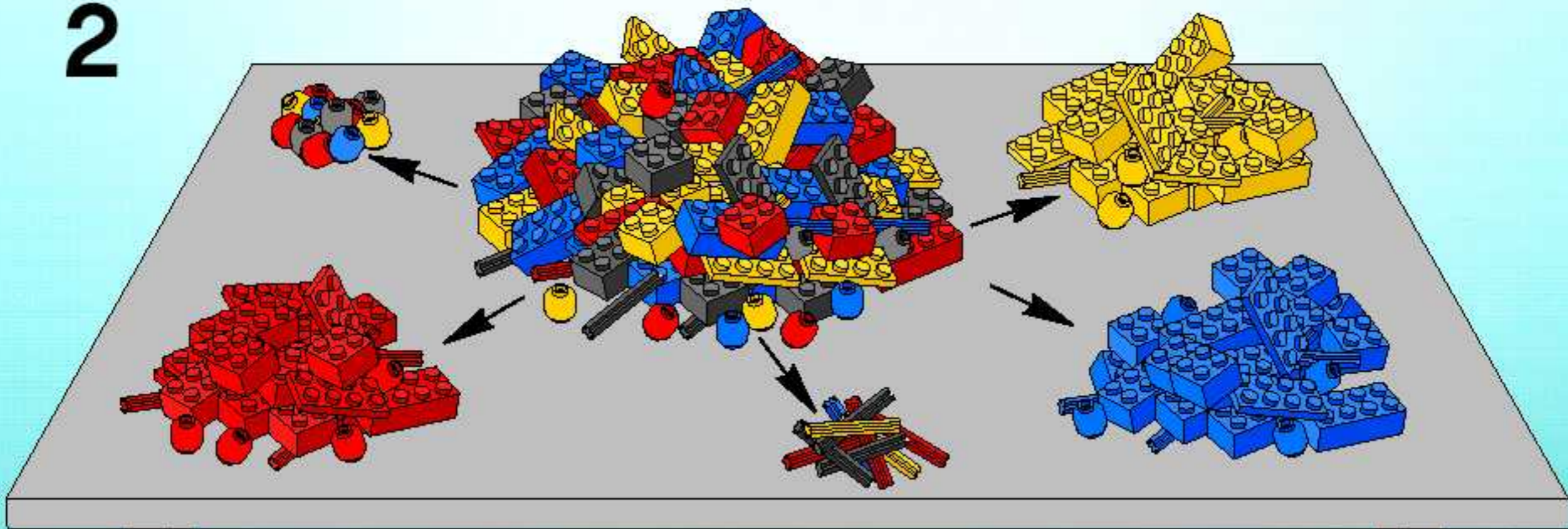



3

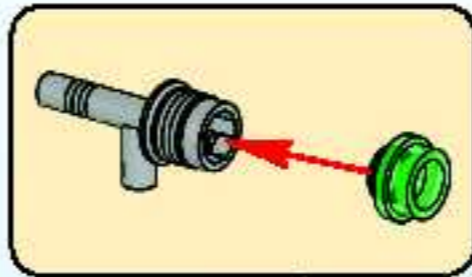
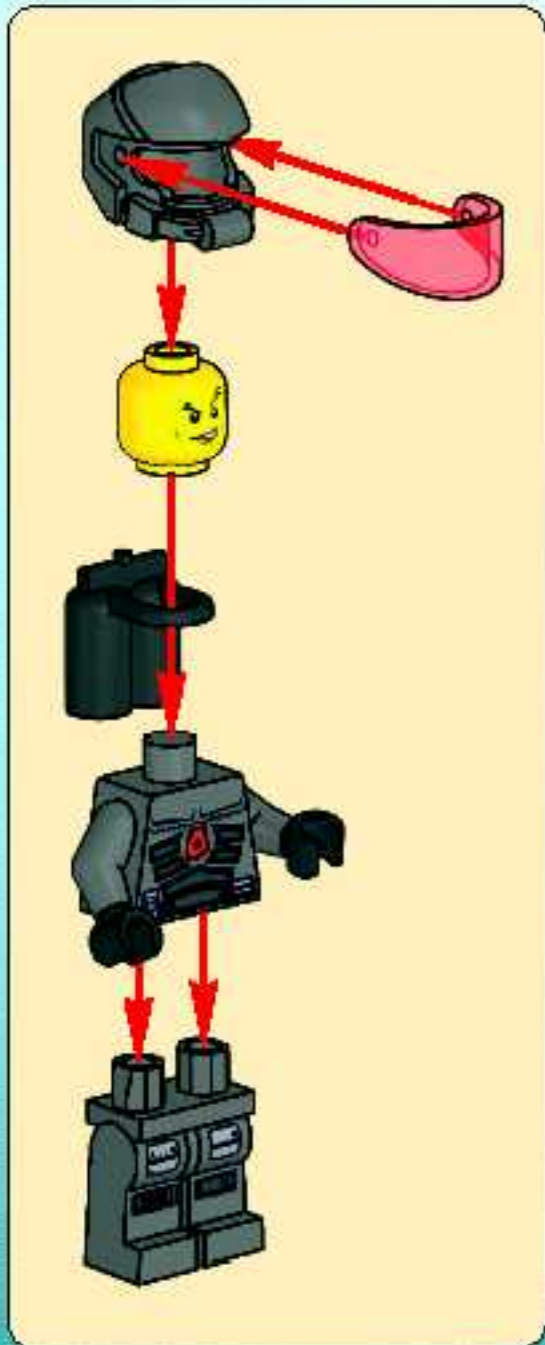

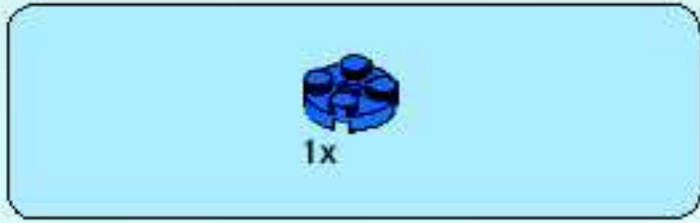

1

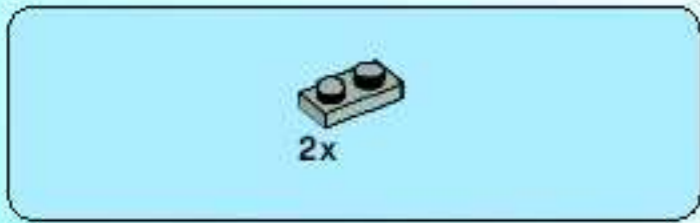

2

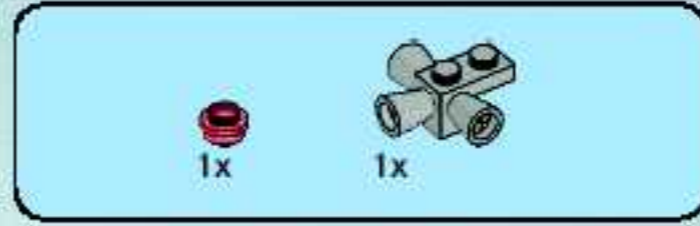
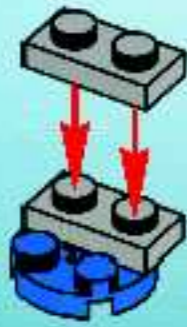

3

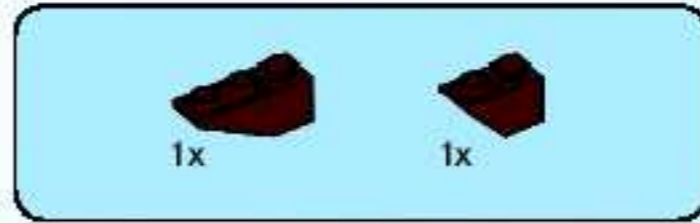

4

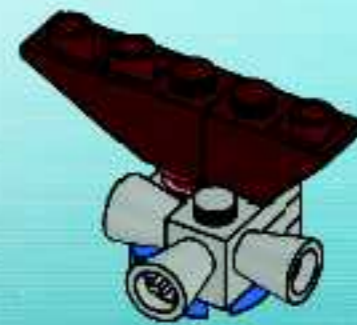

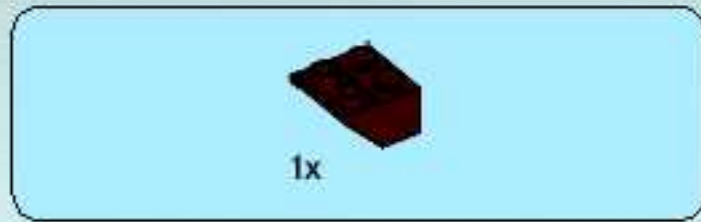

5

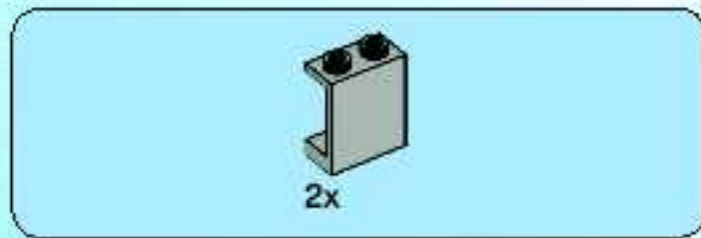
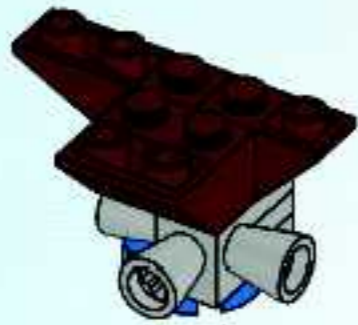

6

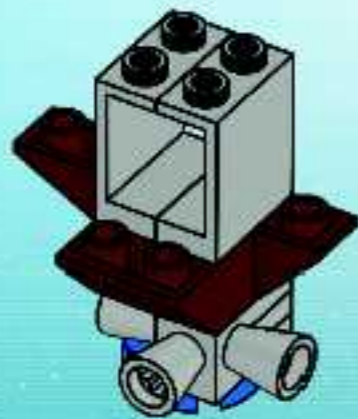

7

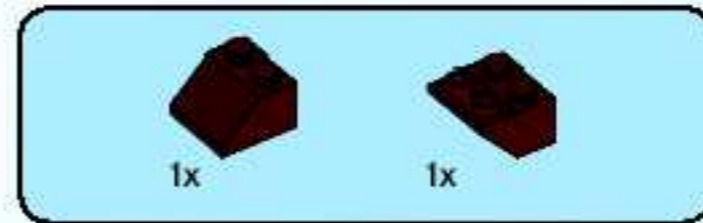
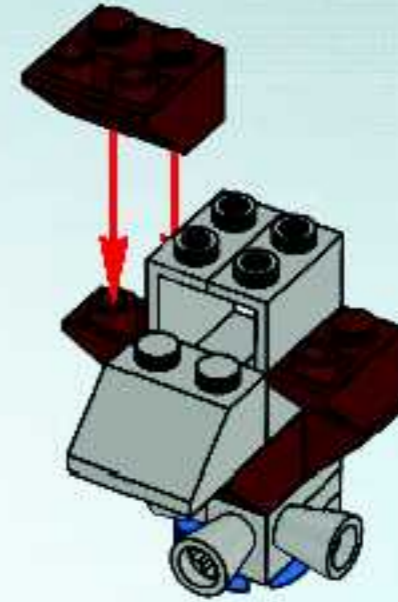

8

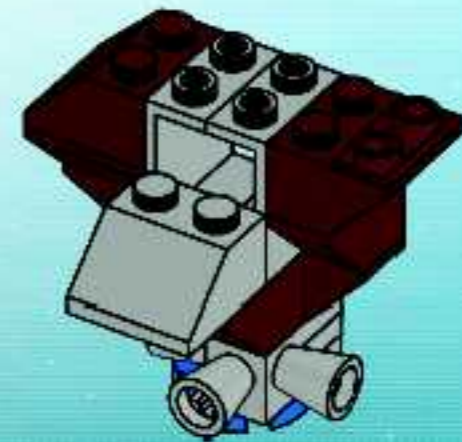

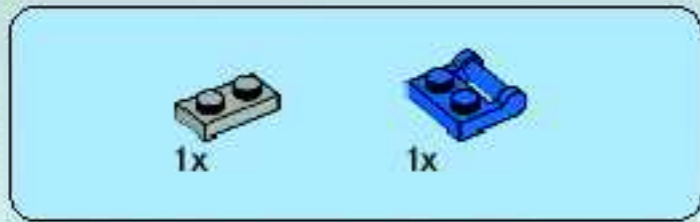

9

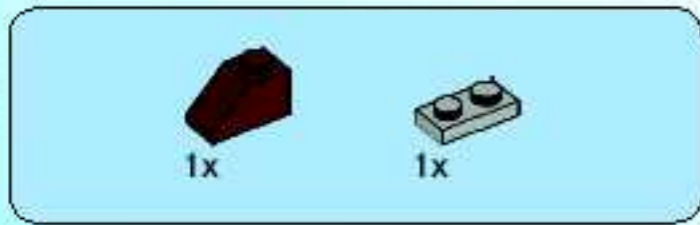
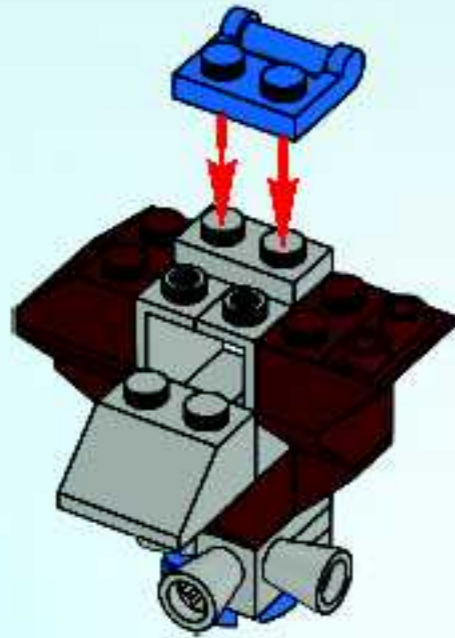

10

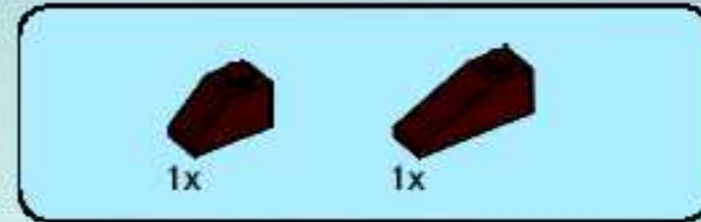
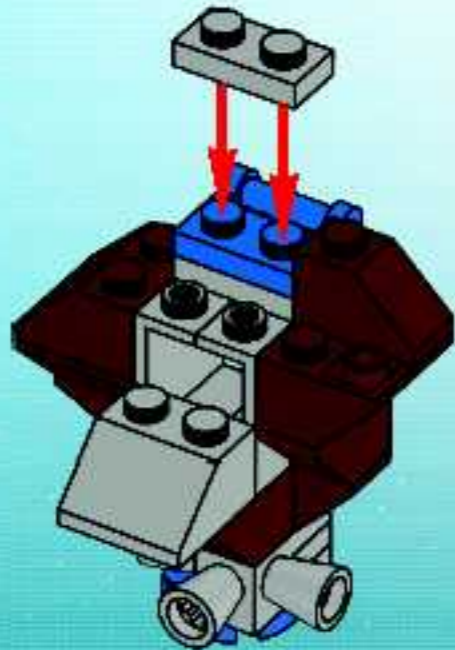

11

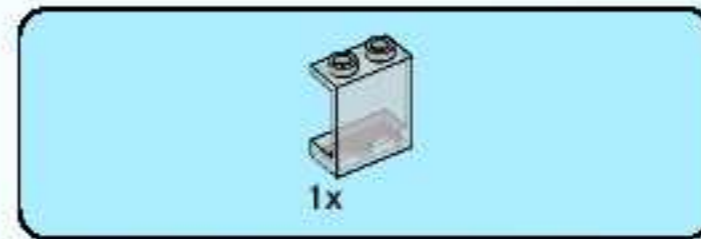
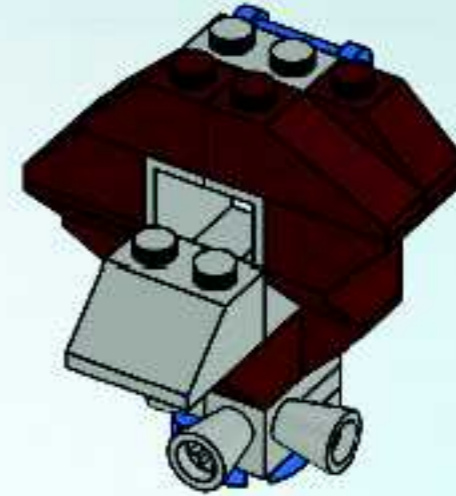

12

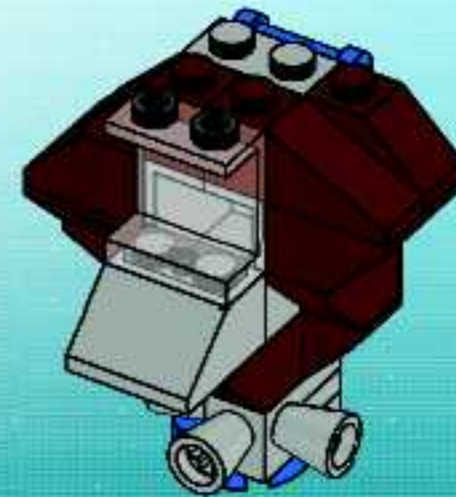



13

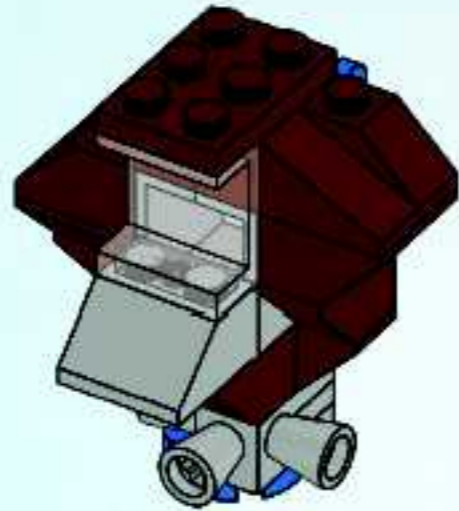

14

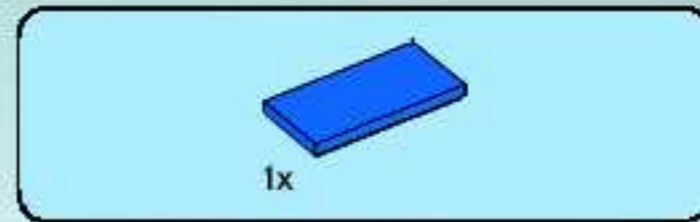
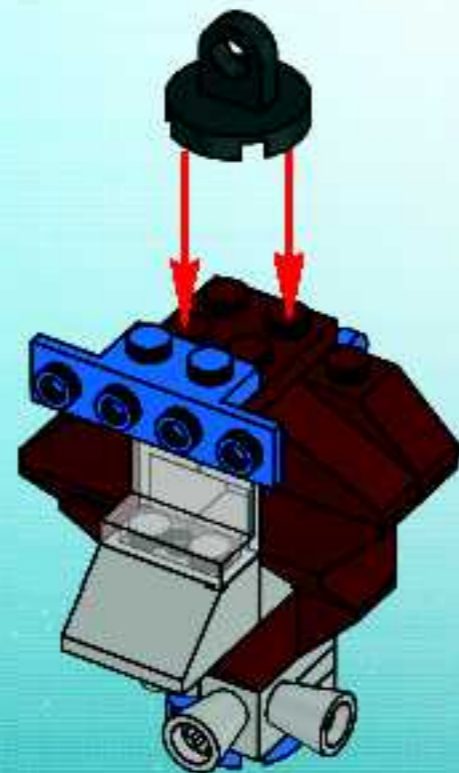

15

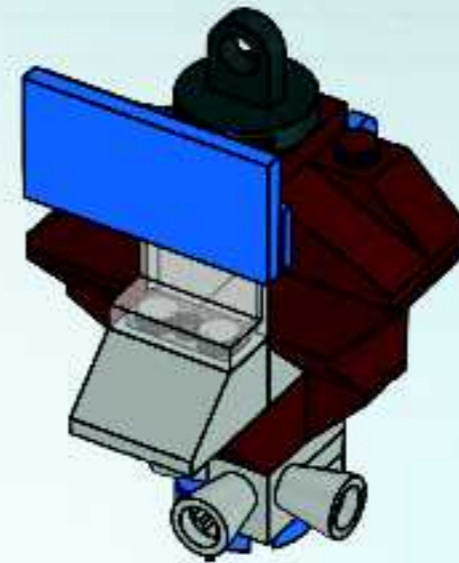

16



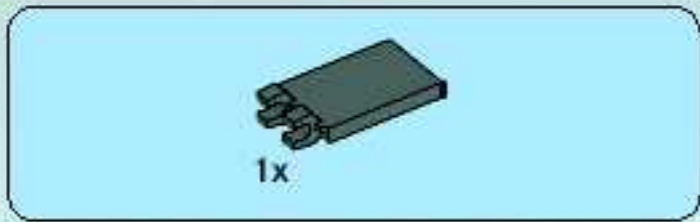

17



18

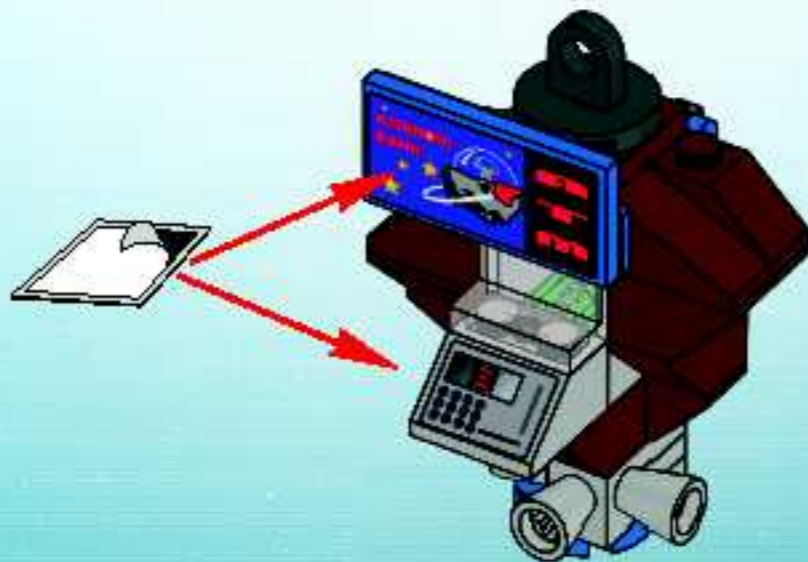



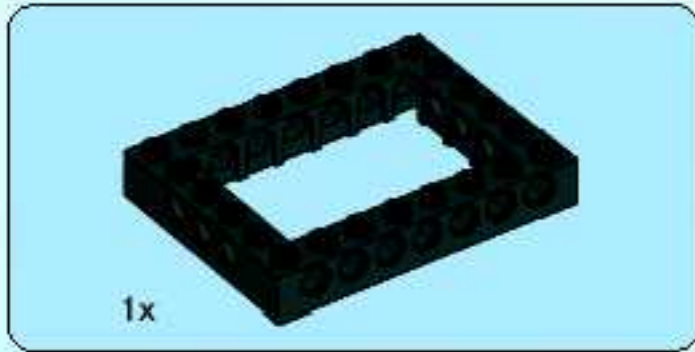
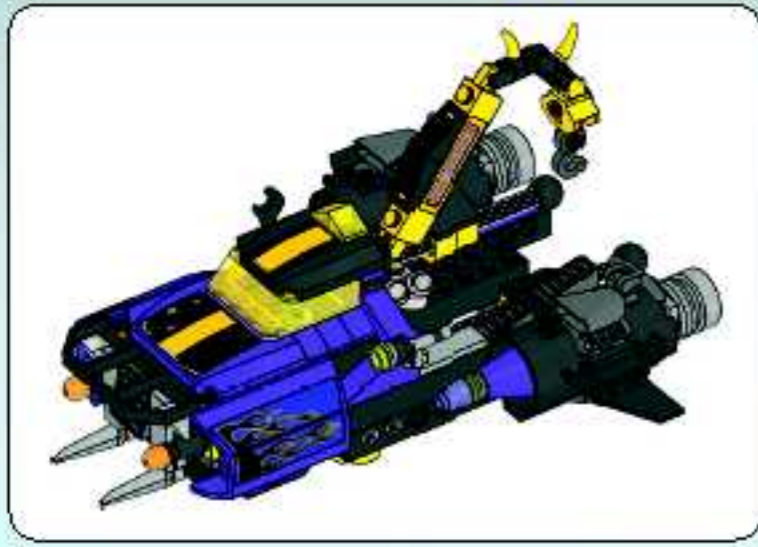

**1**



**2**





3





4

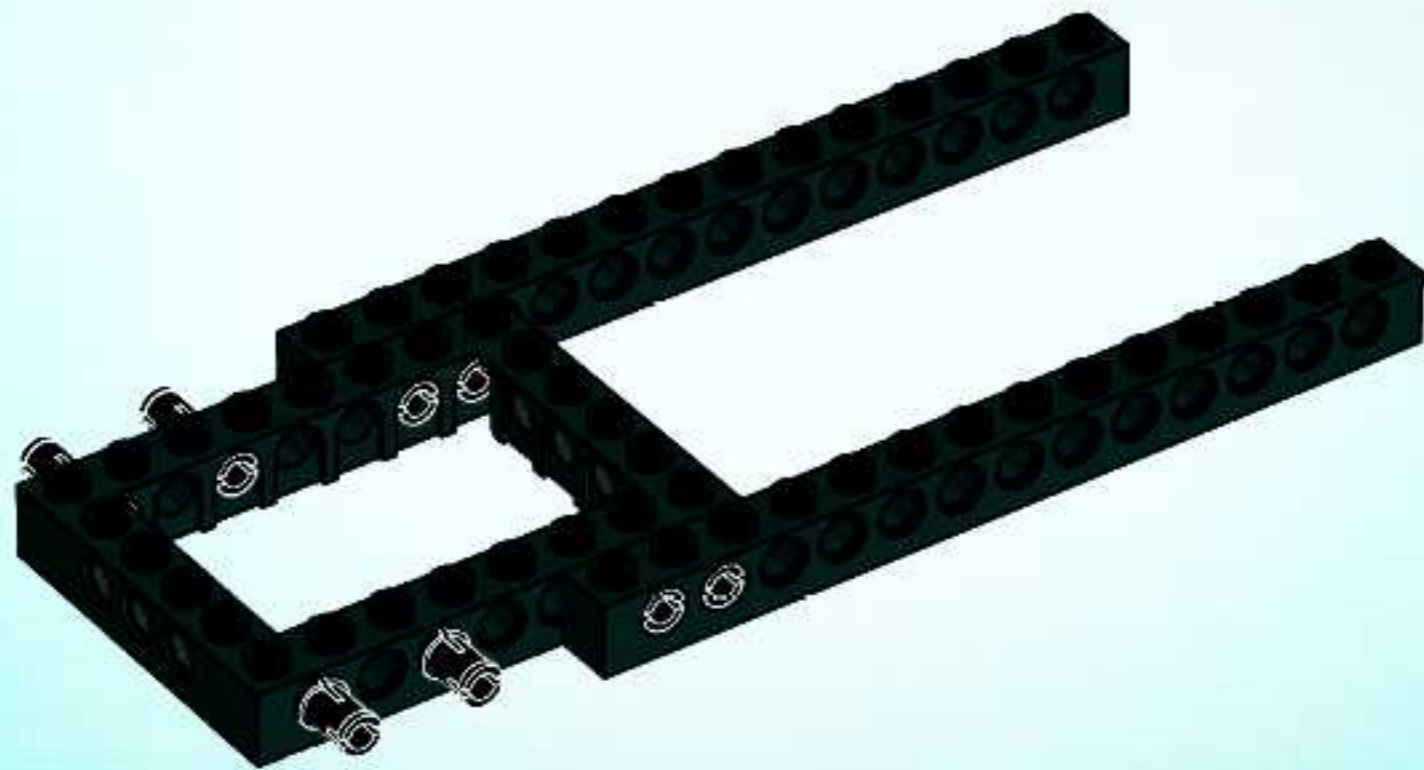

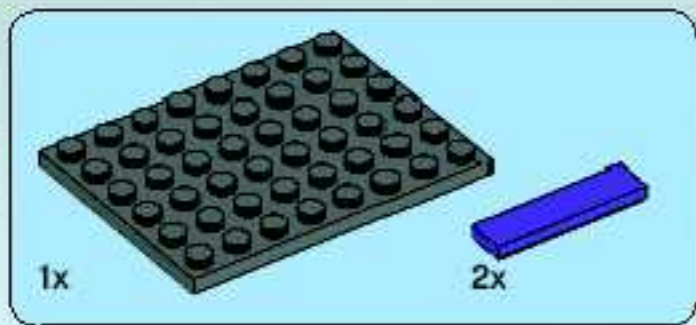

5

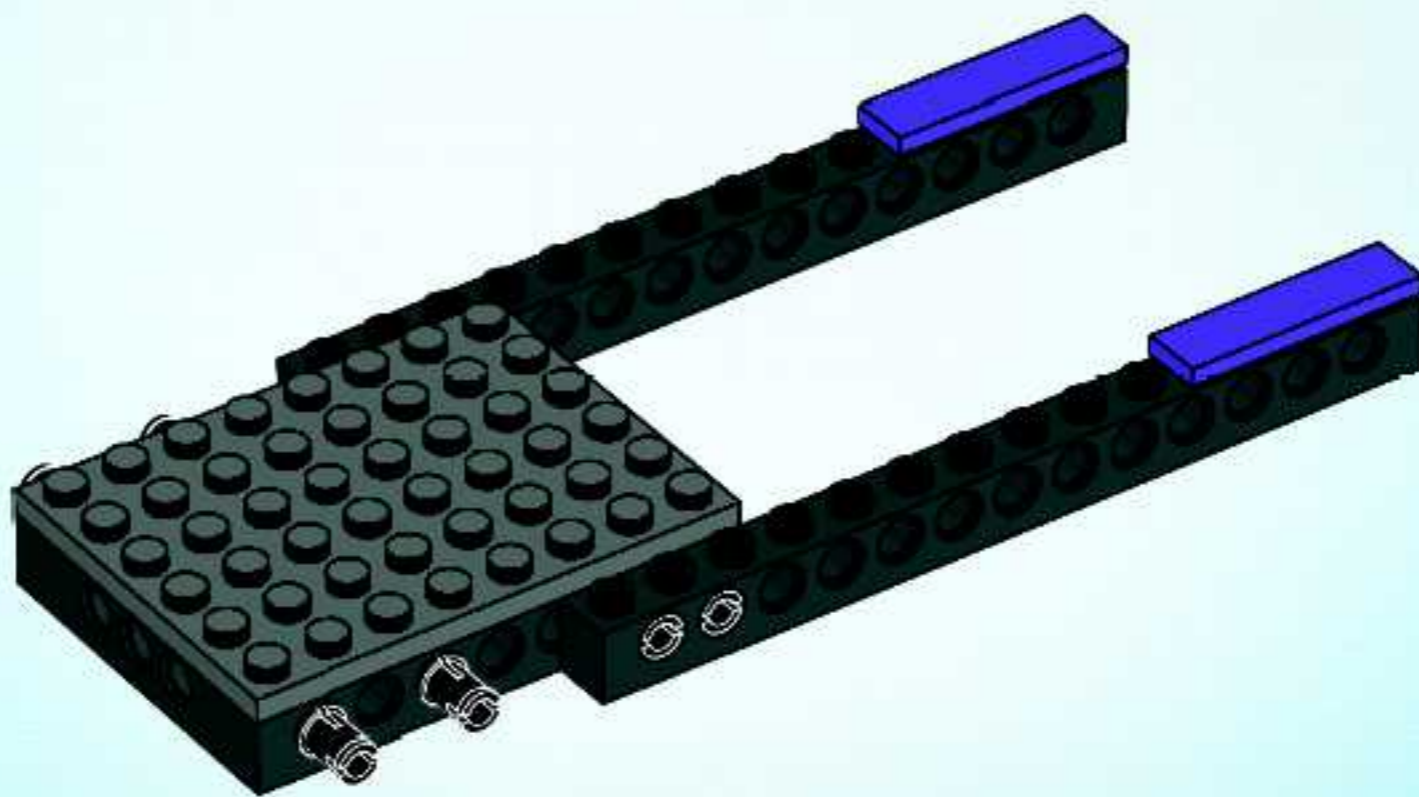

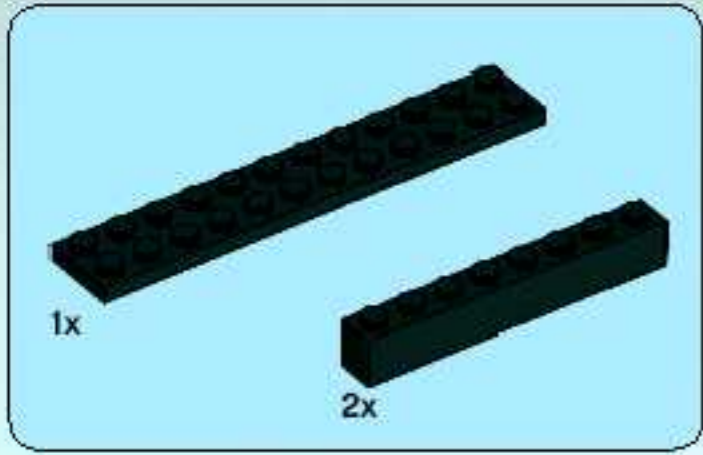

6

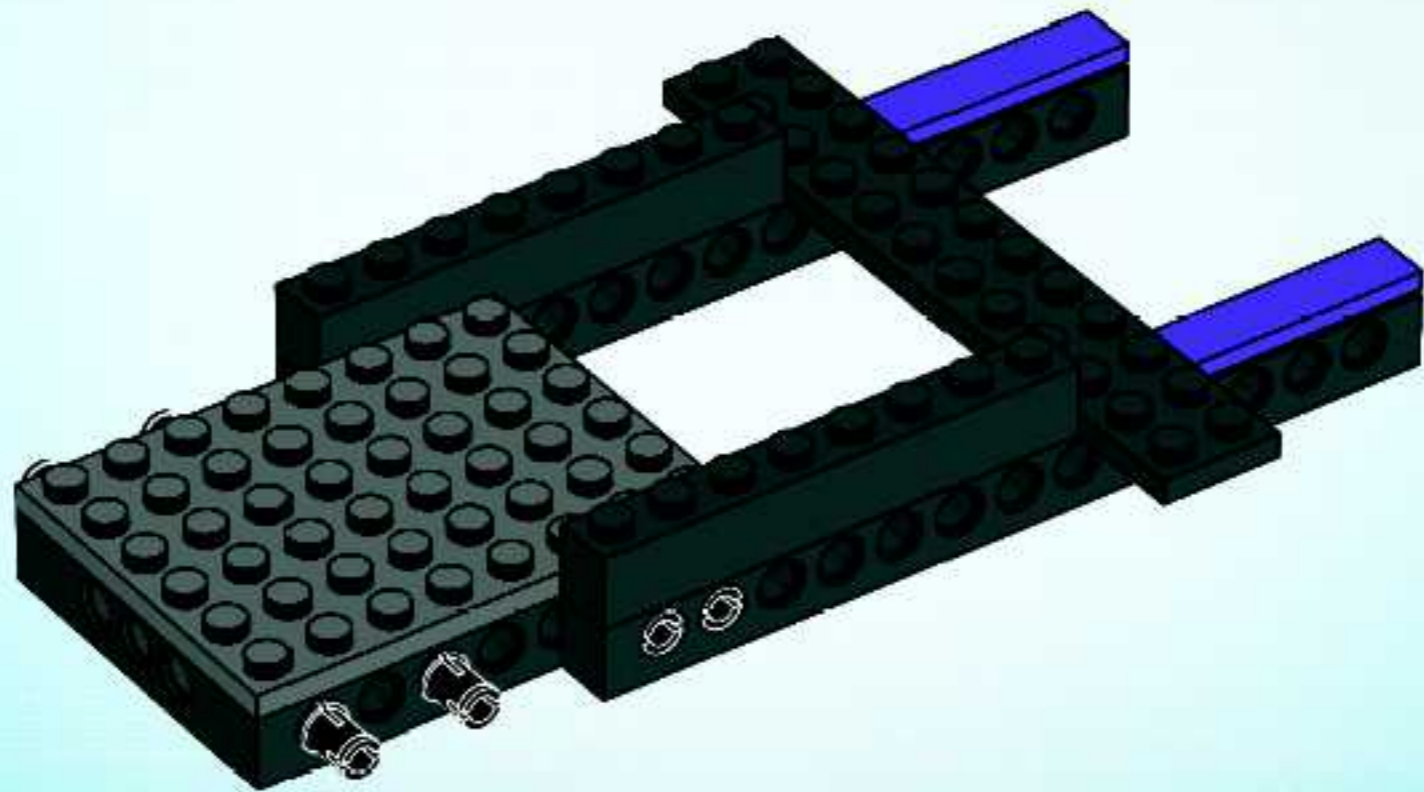



7

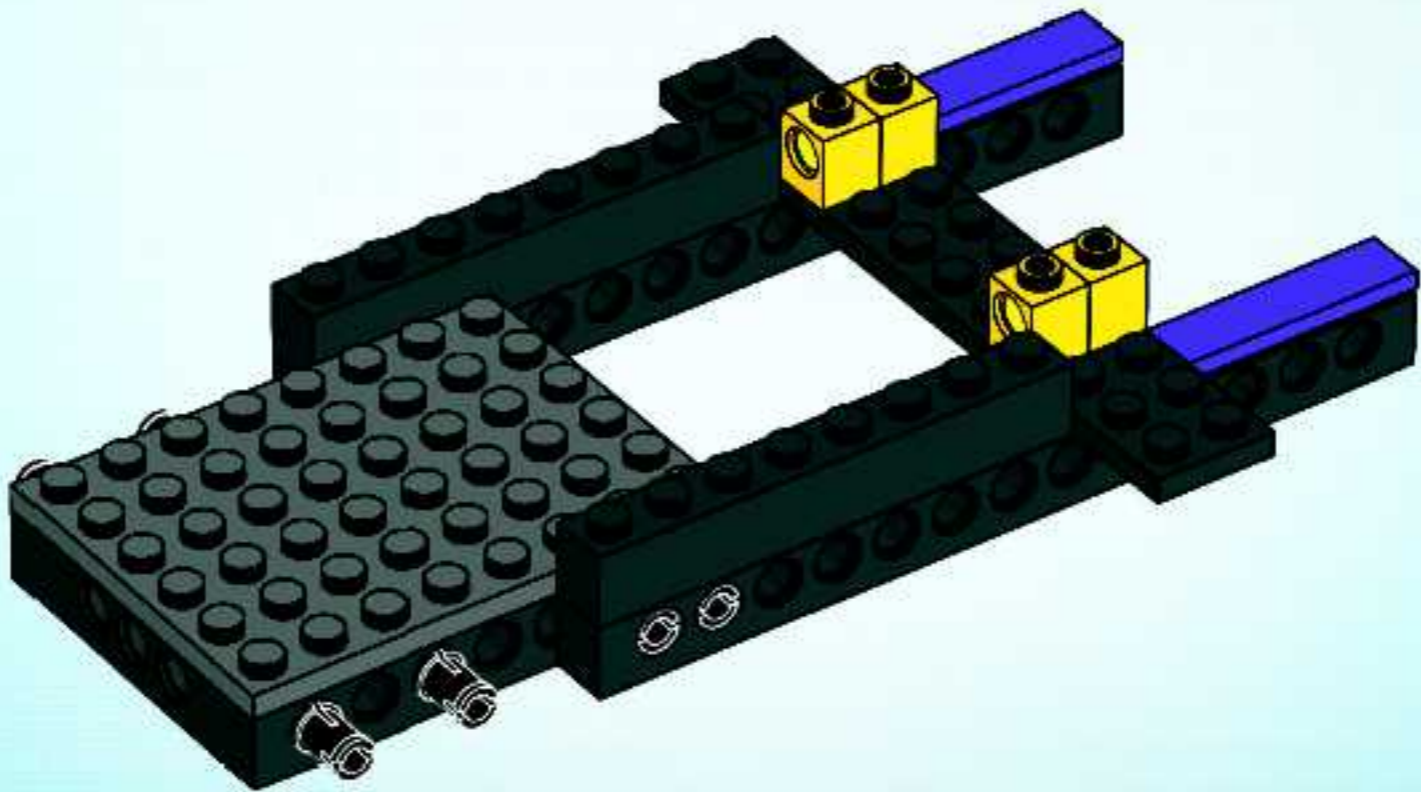



8

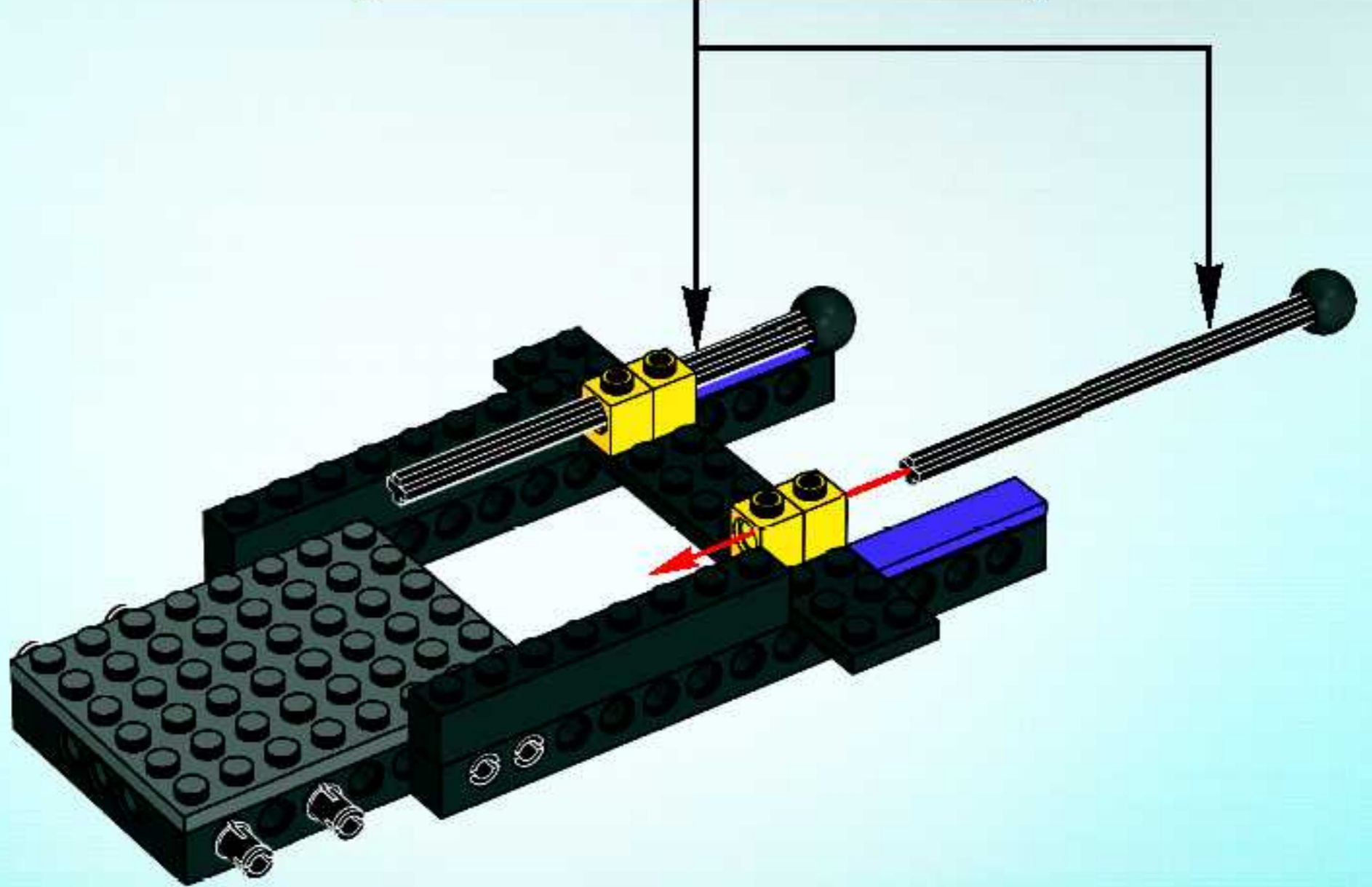
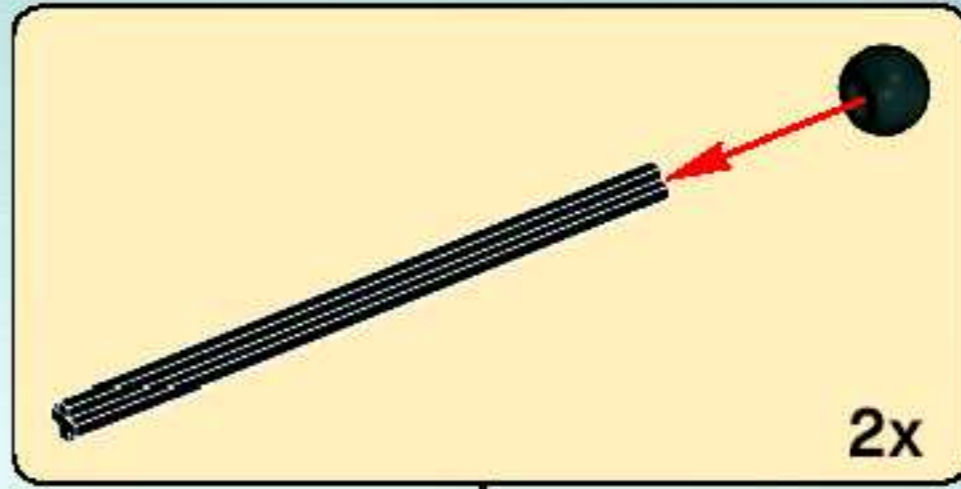

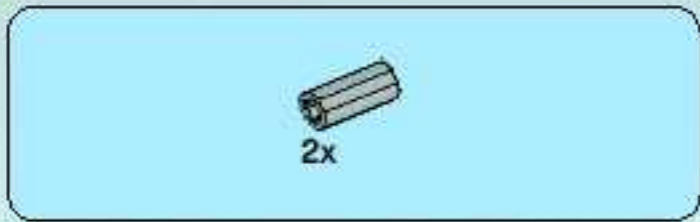

9

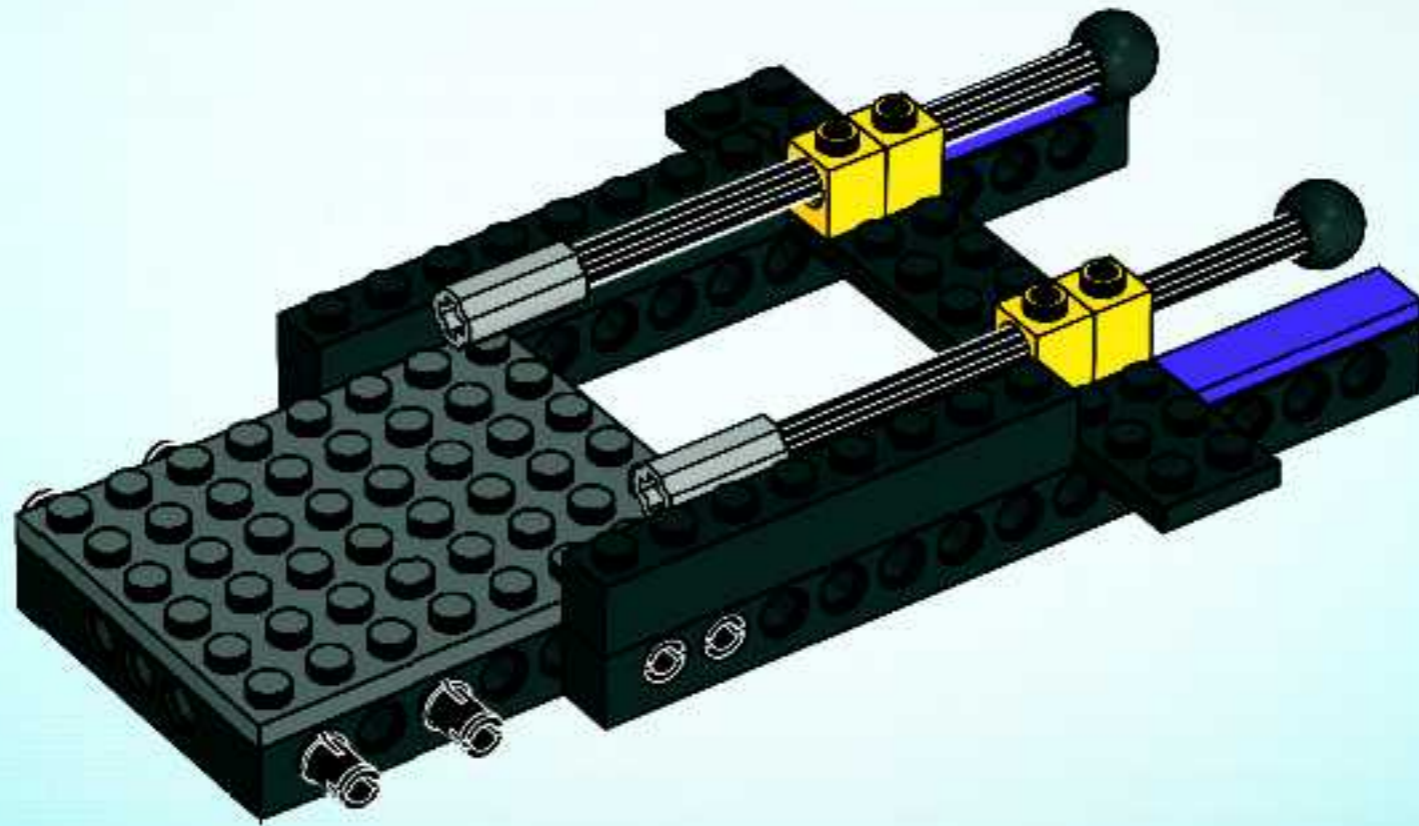



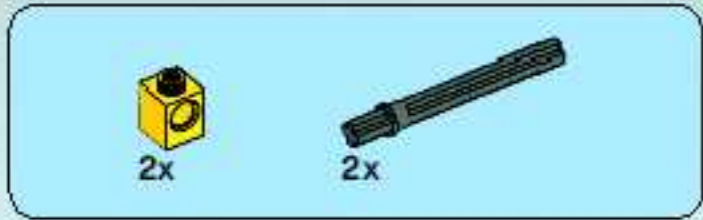

# 10

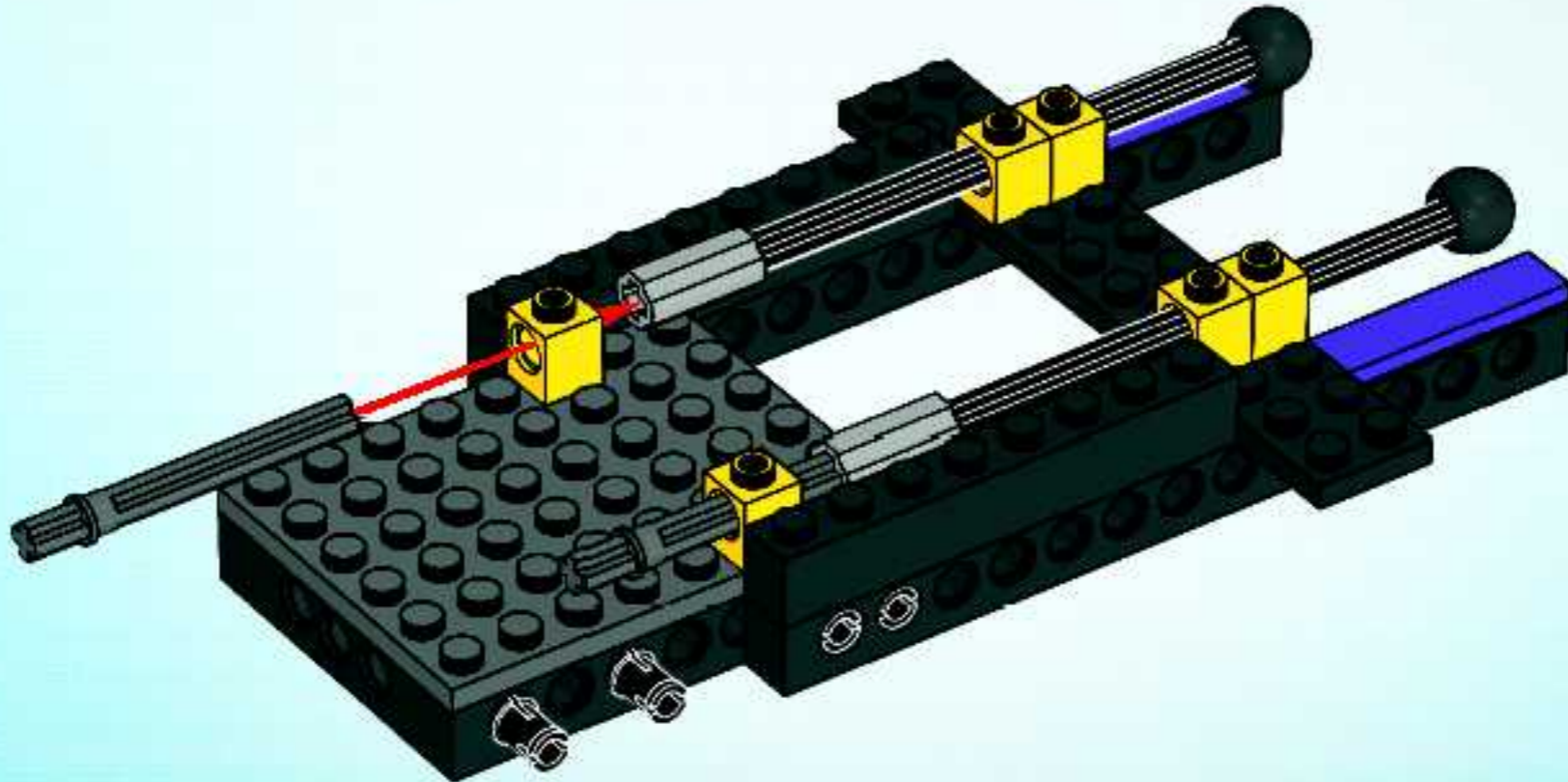

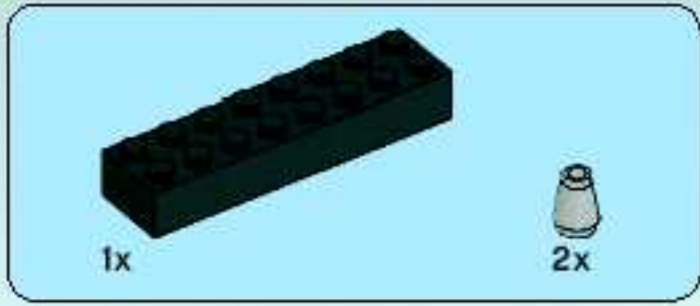

11

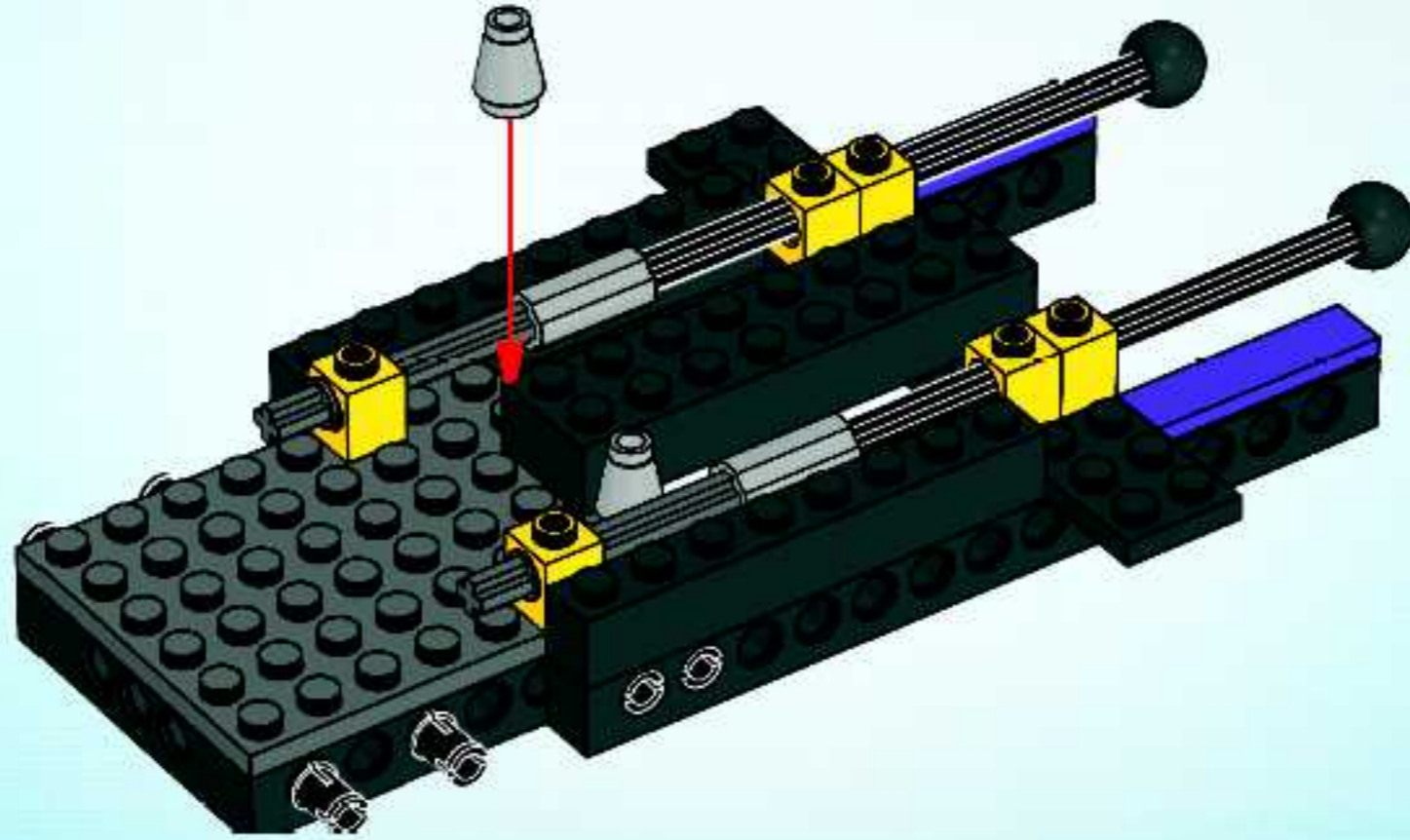

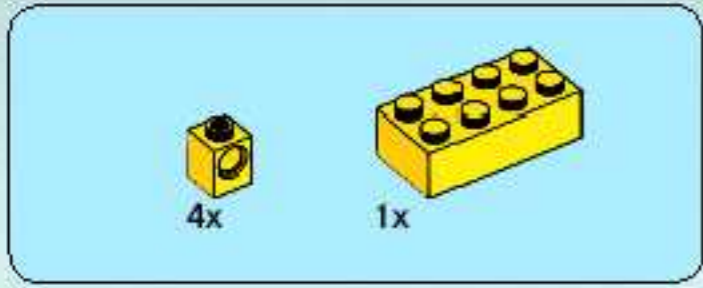

12

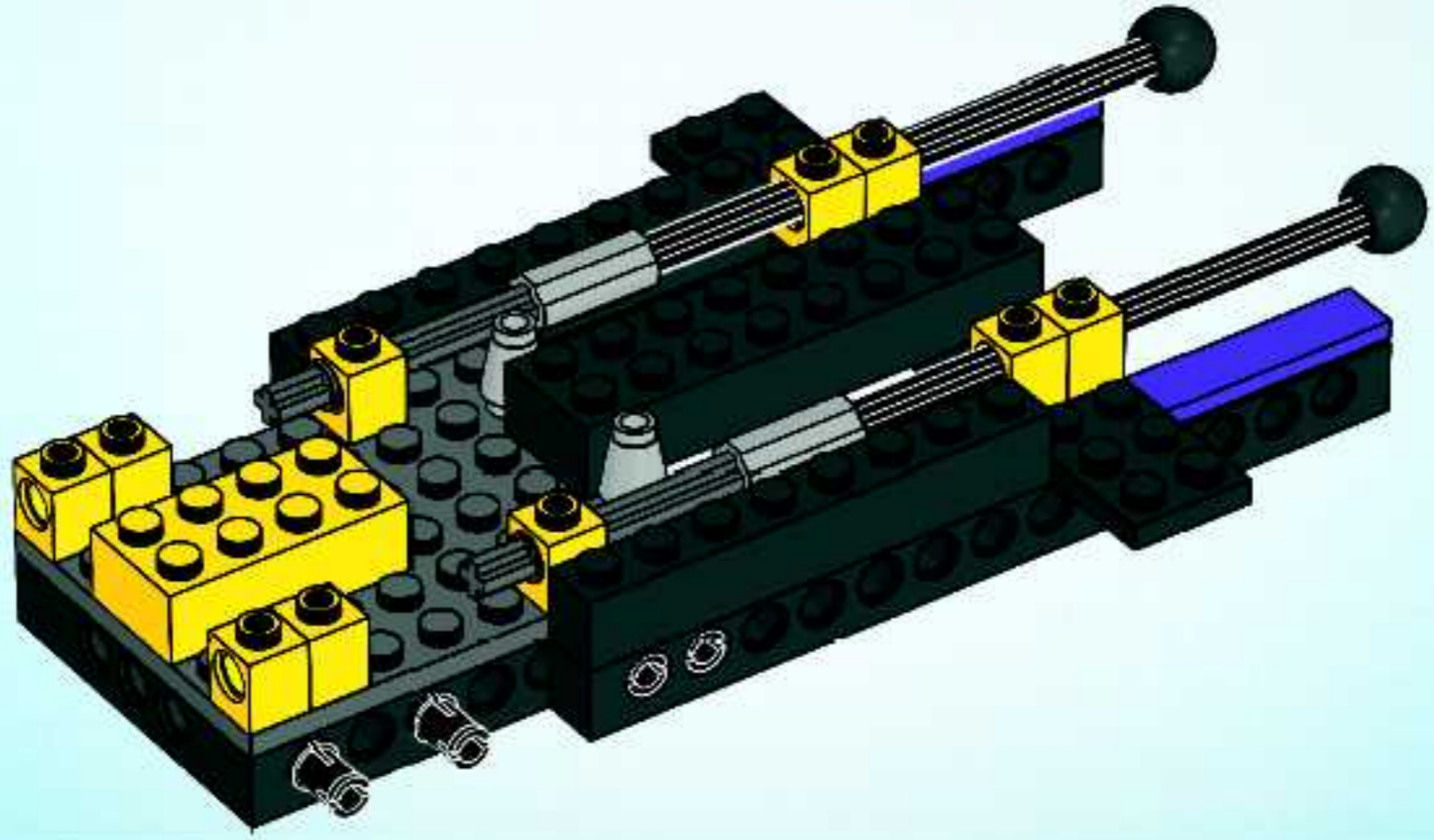



13

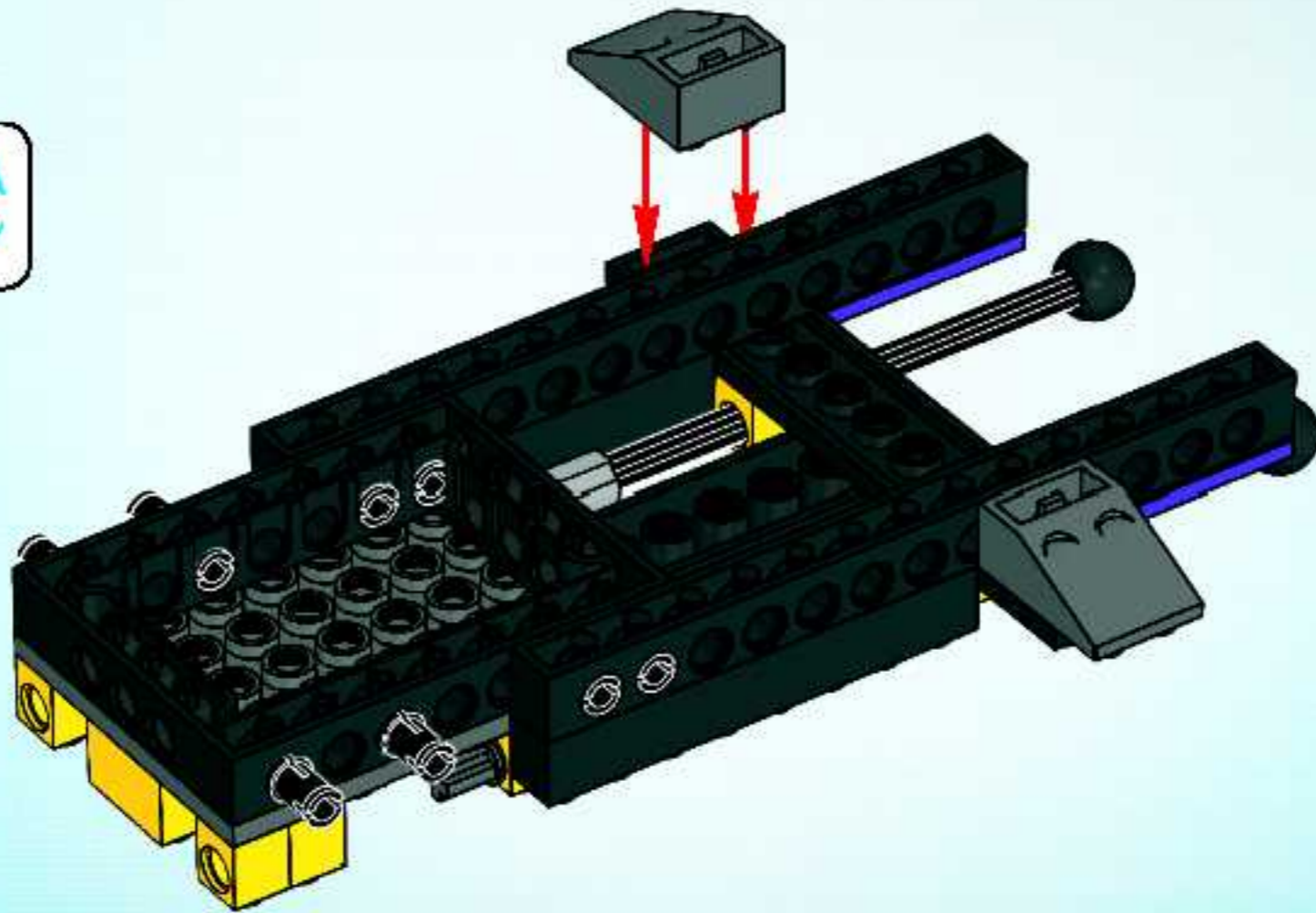



14

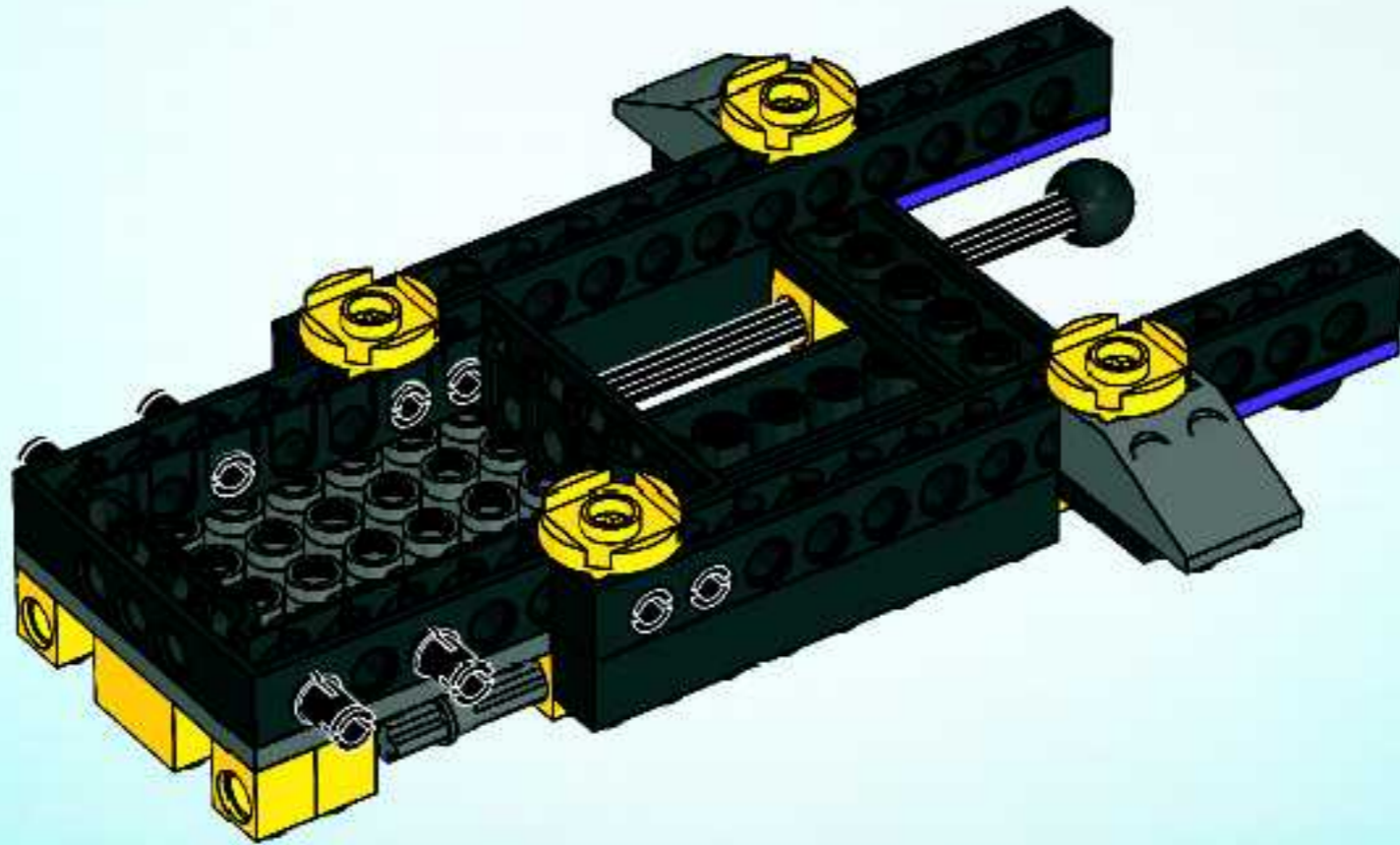

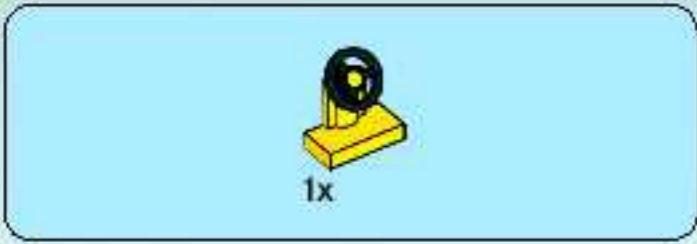

15

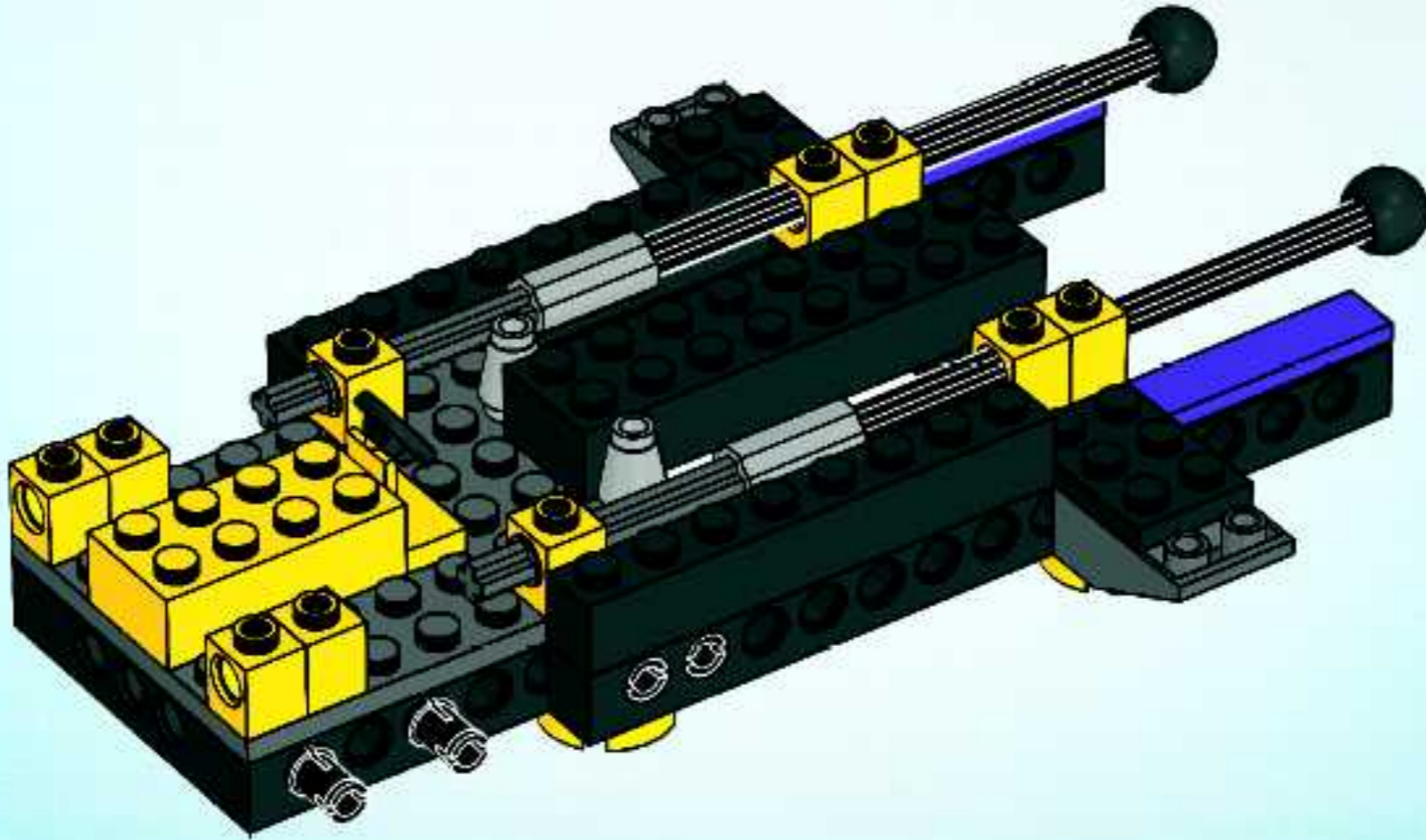

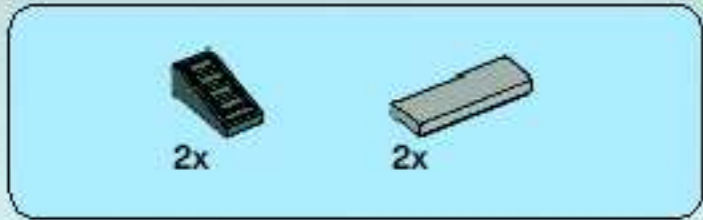

# 16

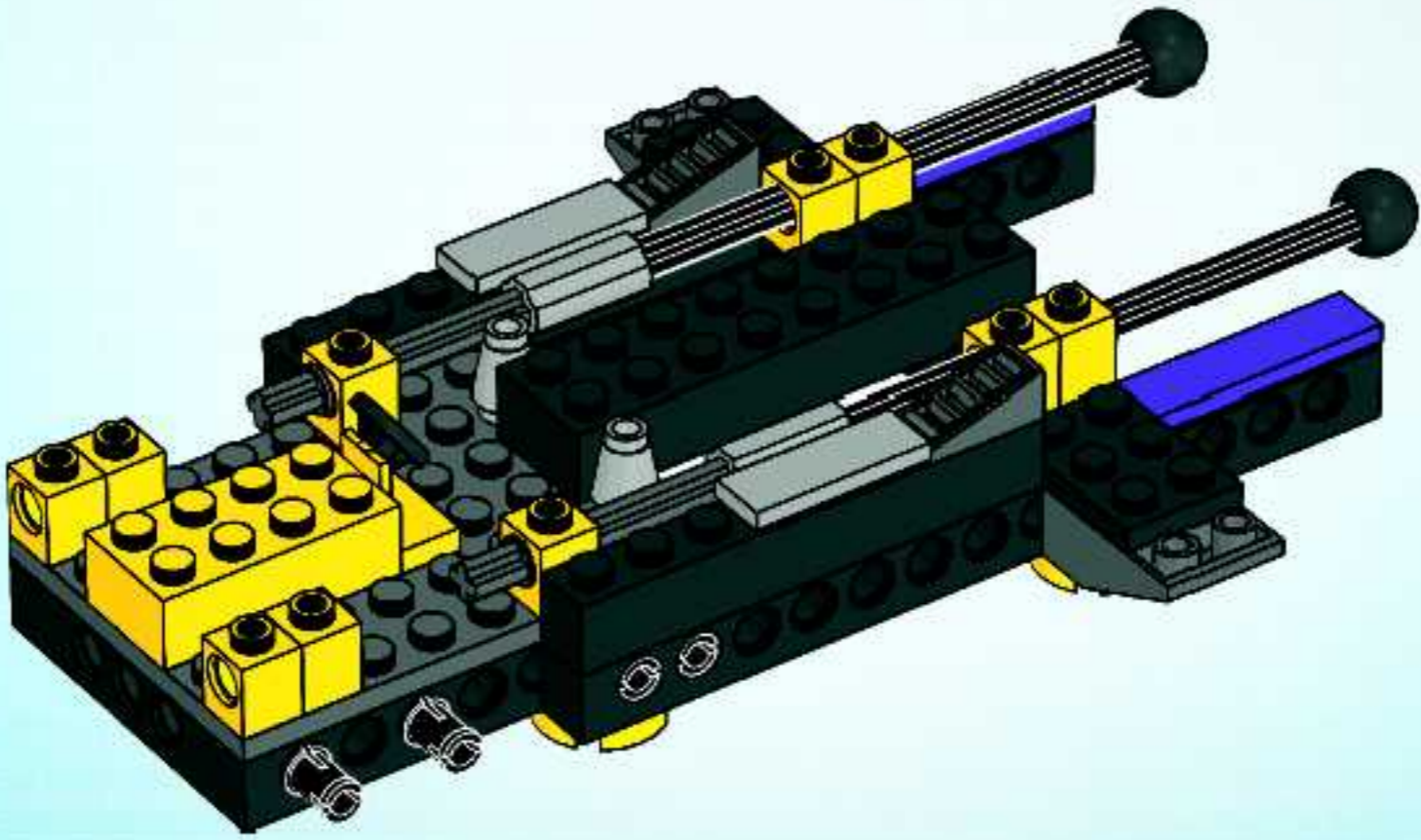

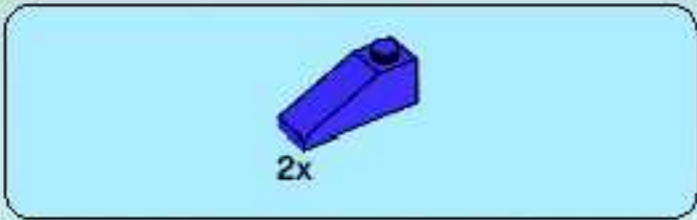

17

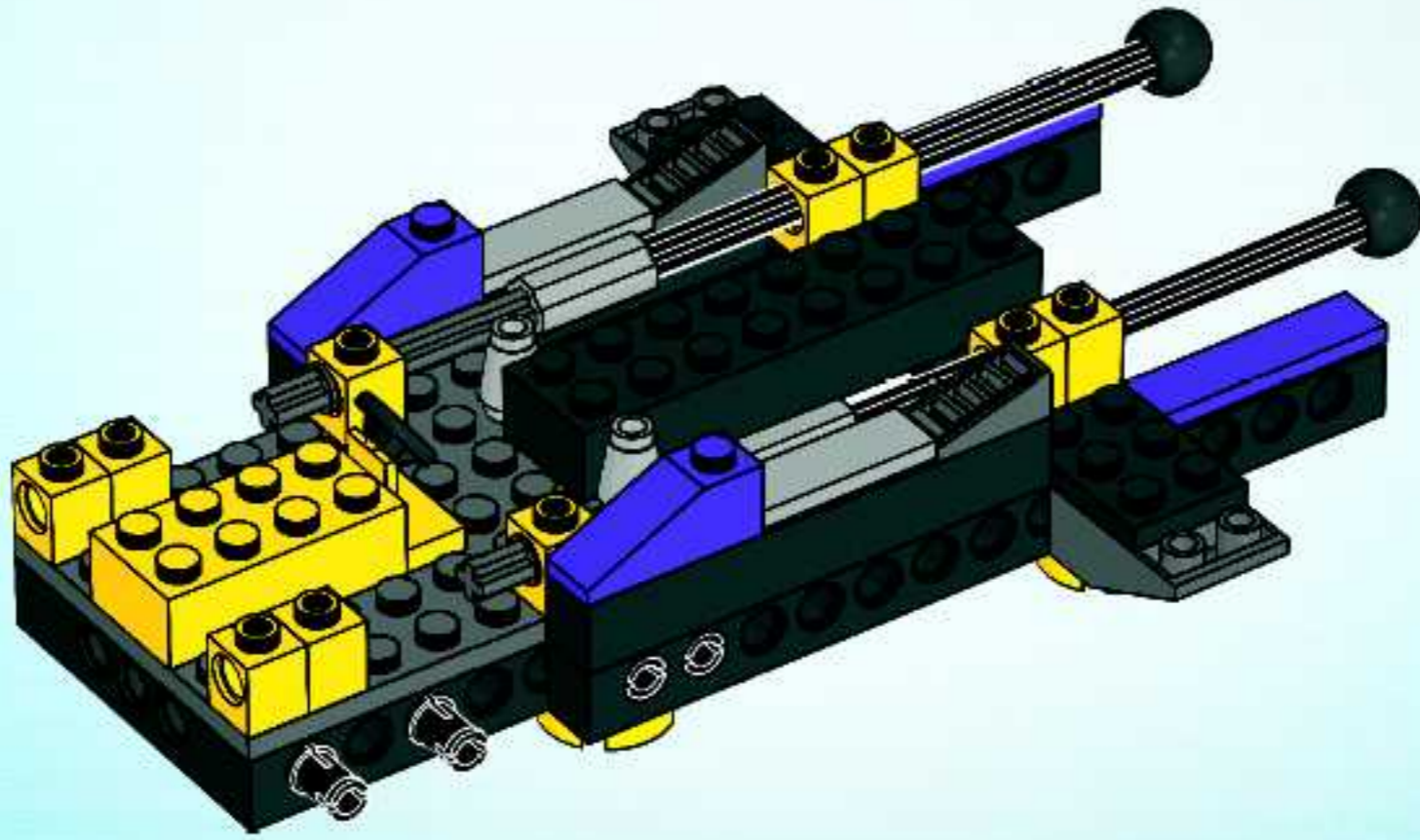



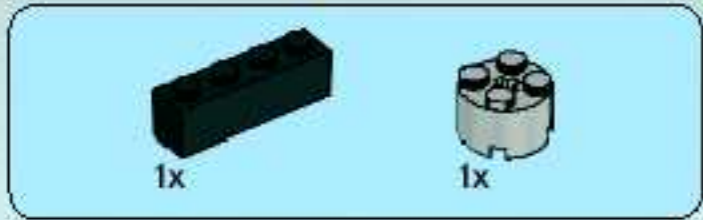

18

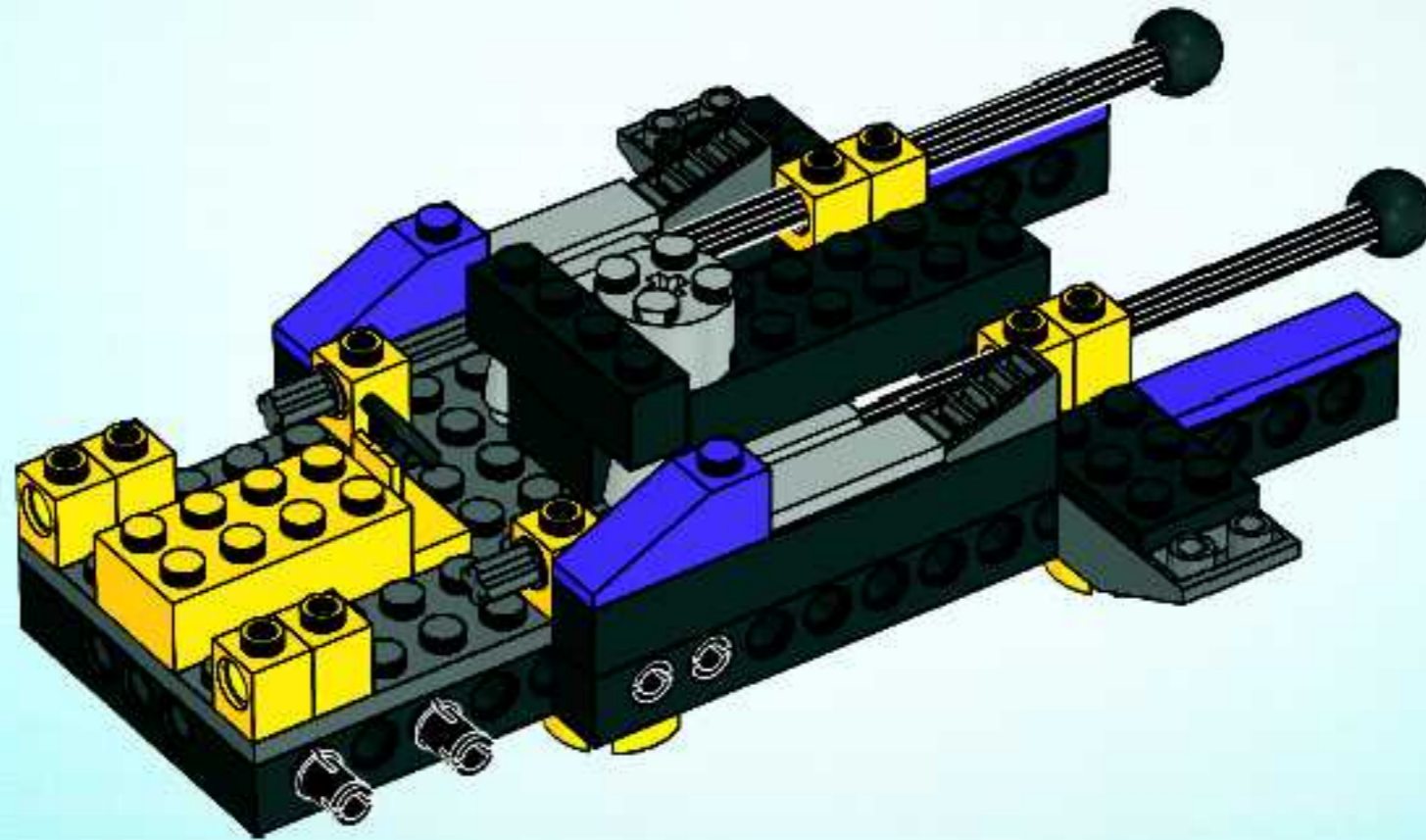

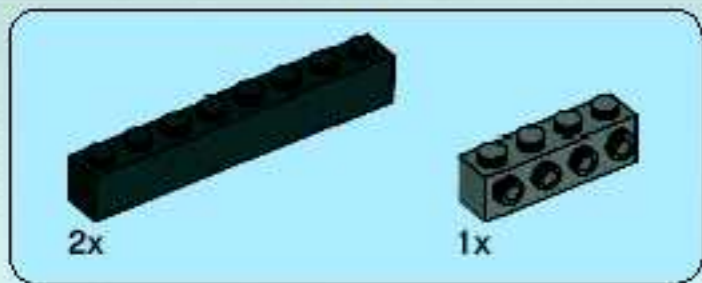

# 19

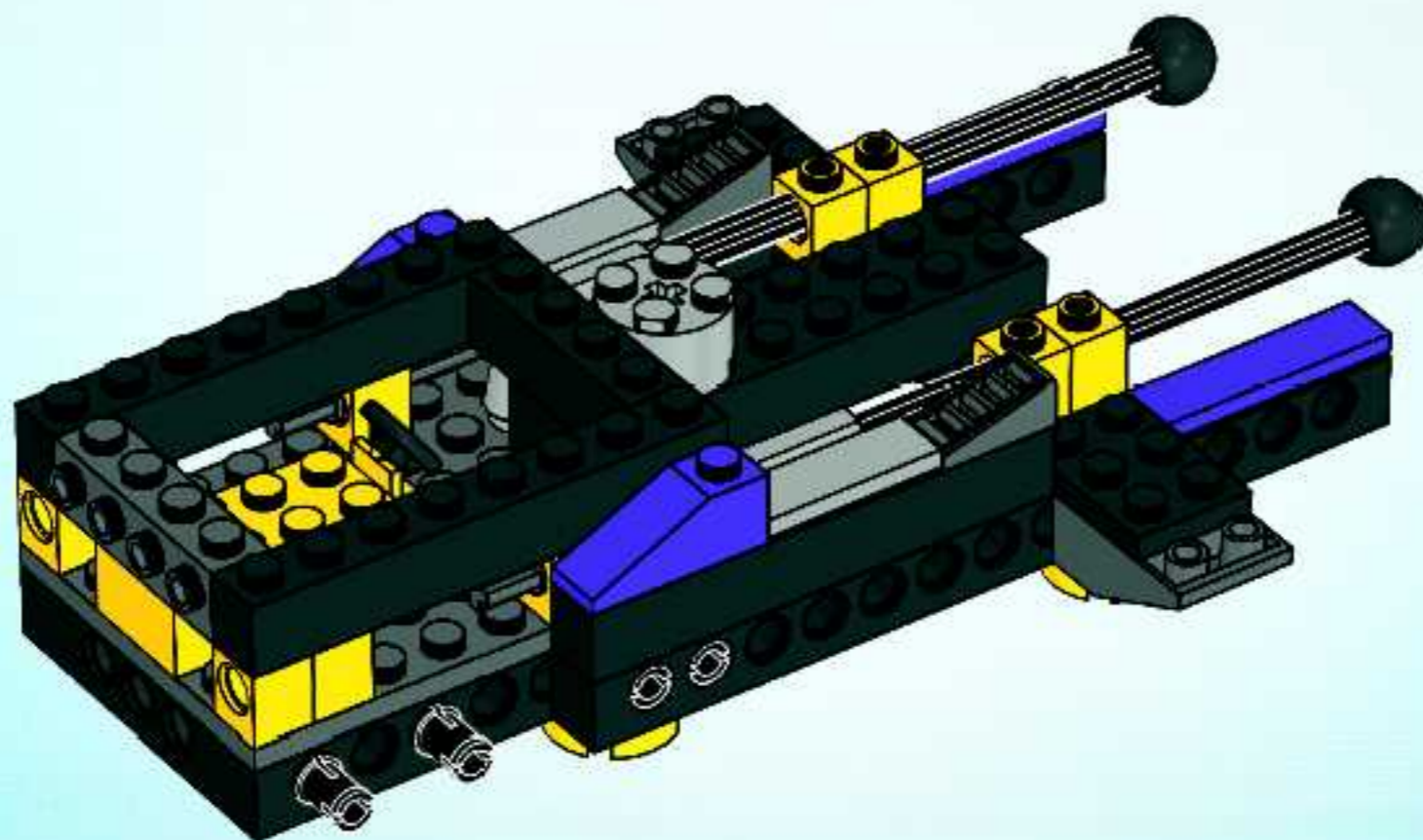

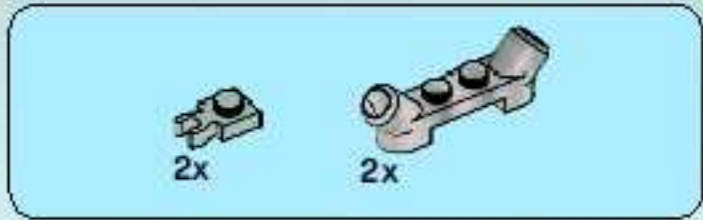

20

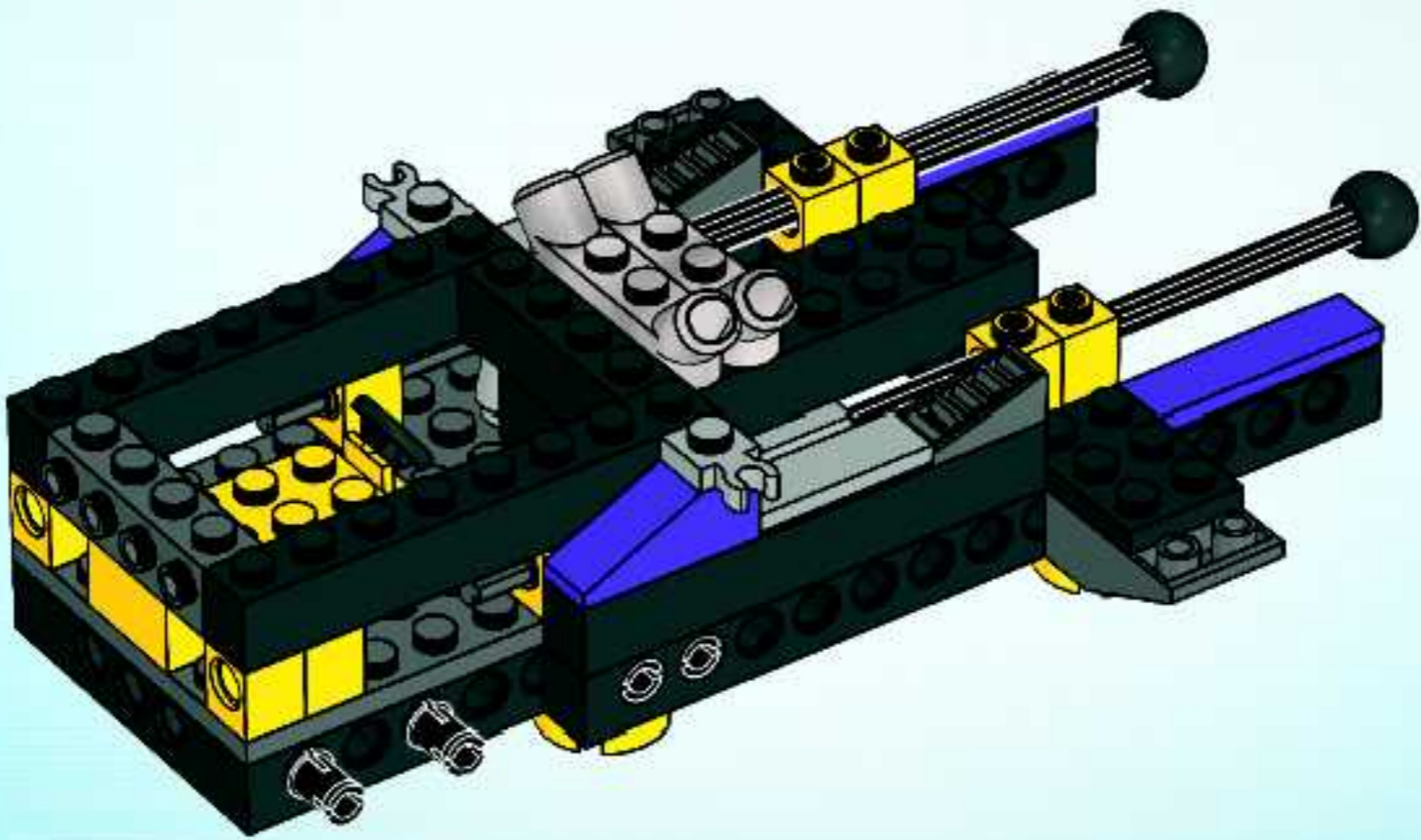

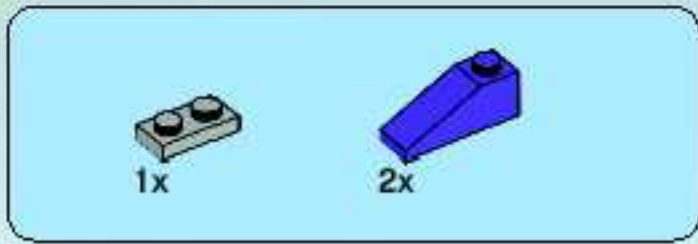

21

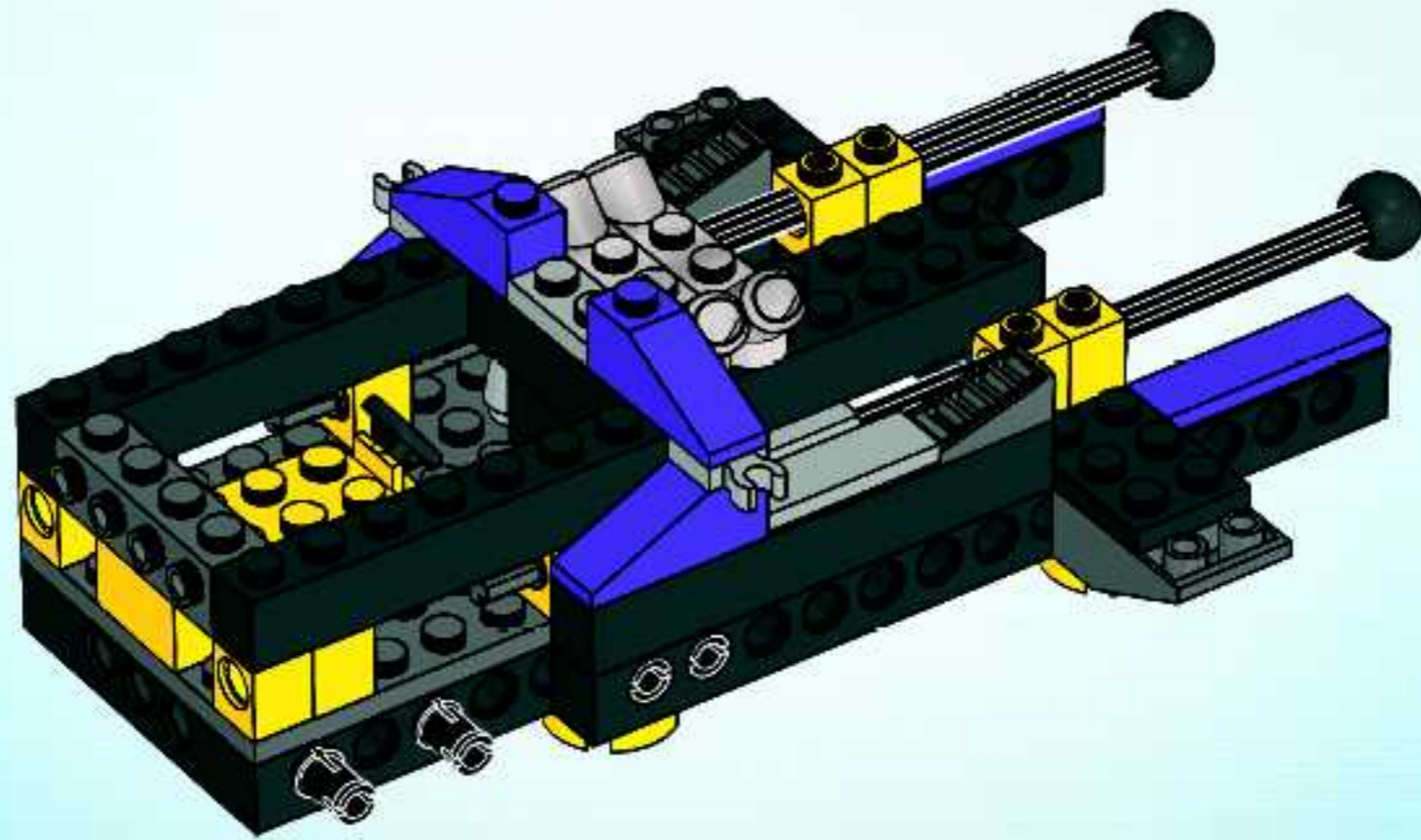



22

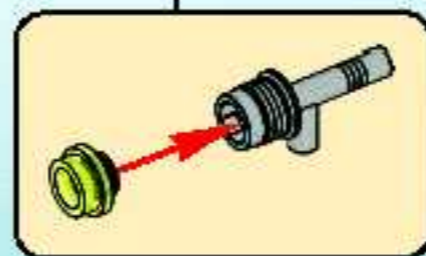
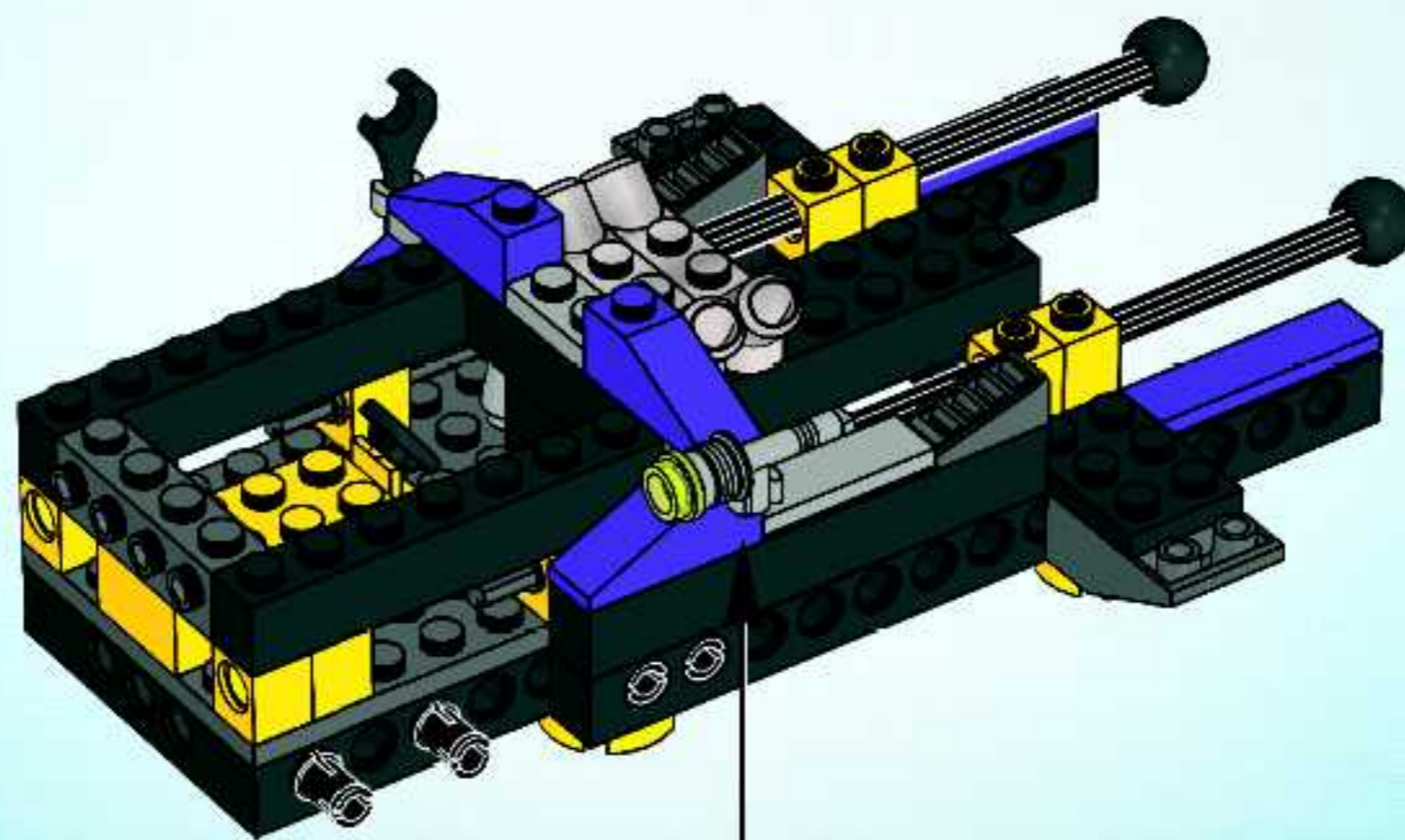

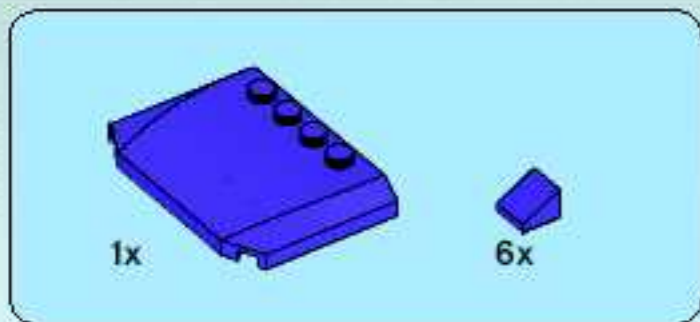

23

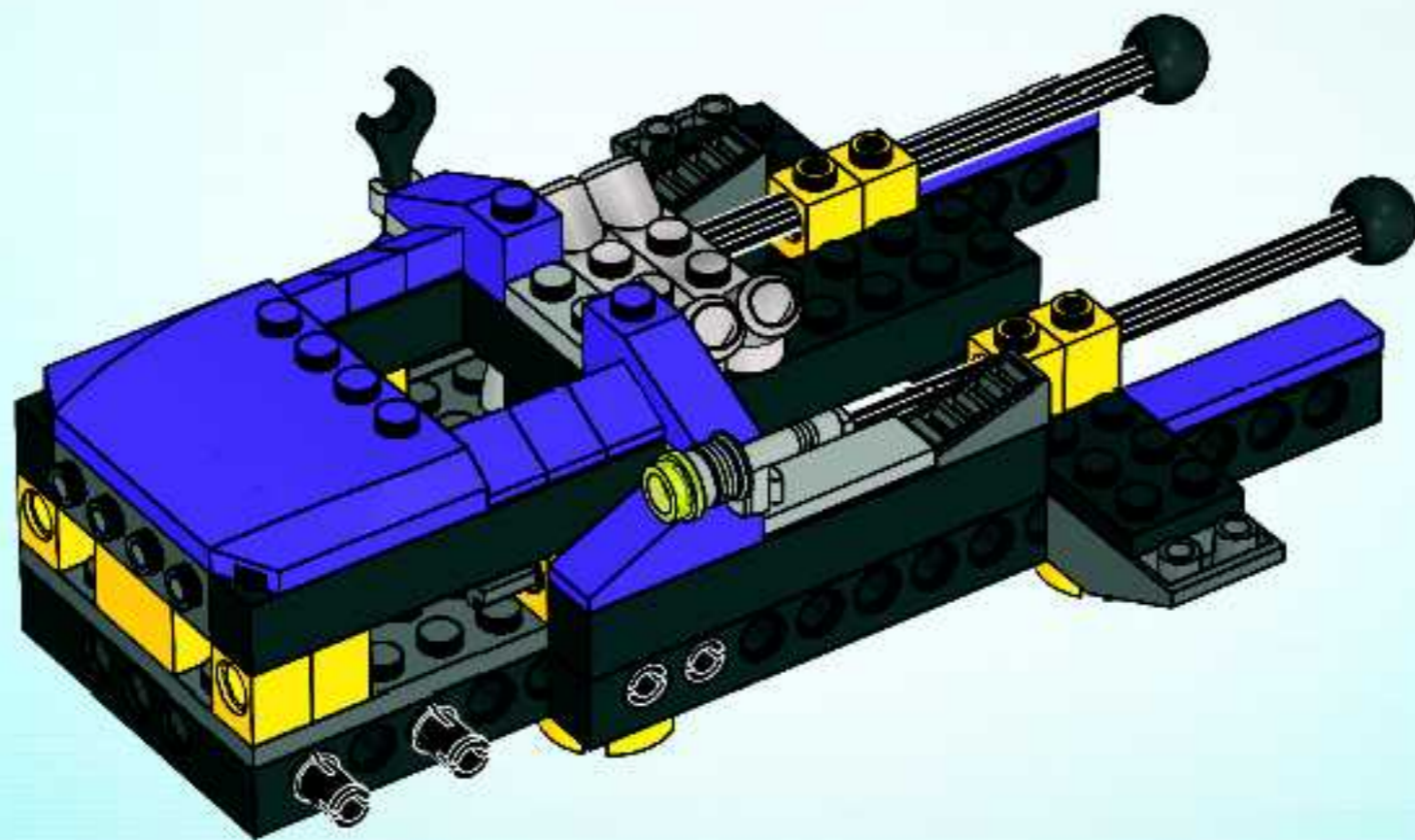



24

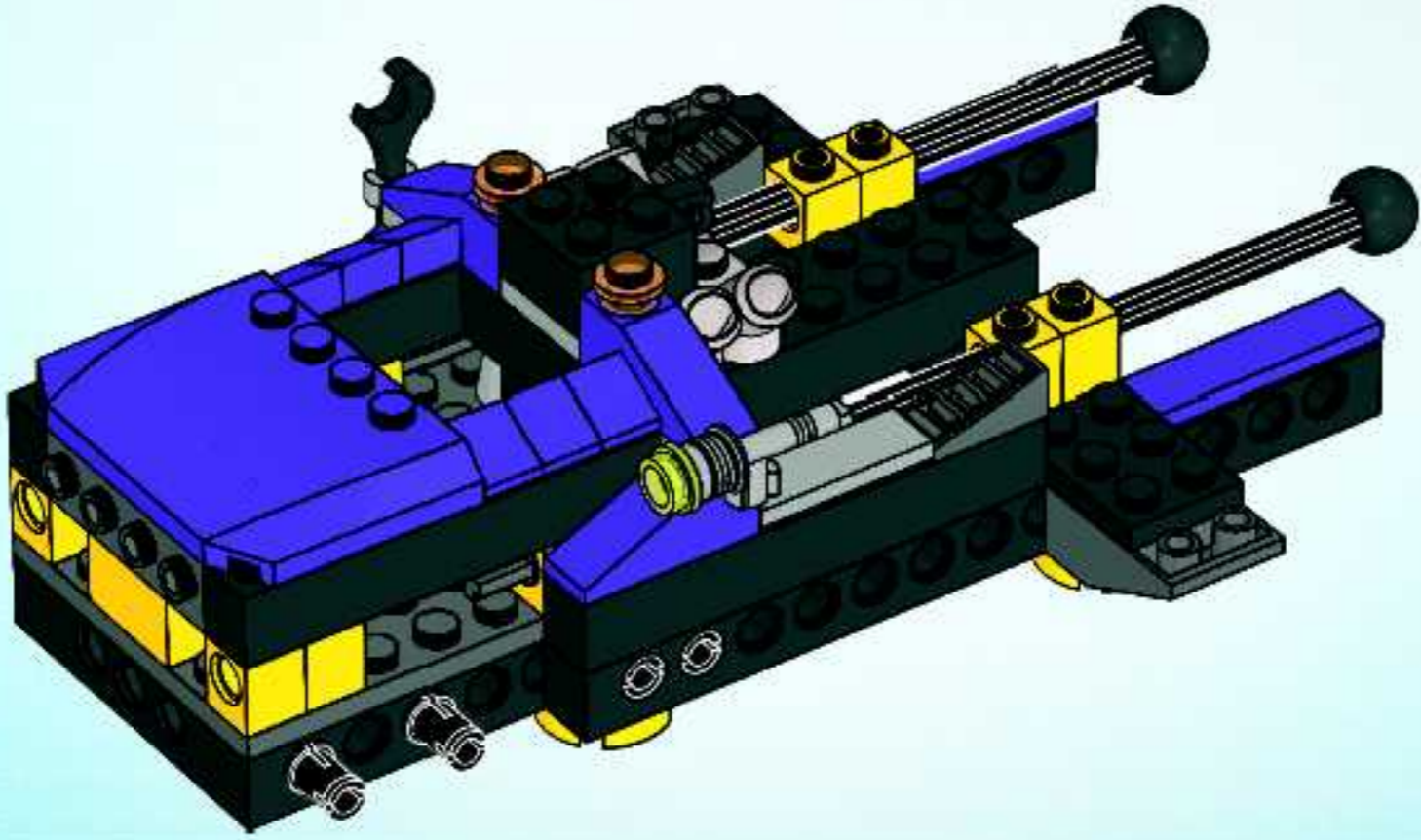

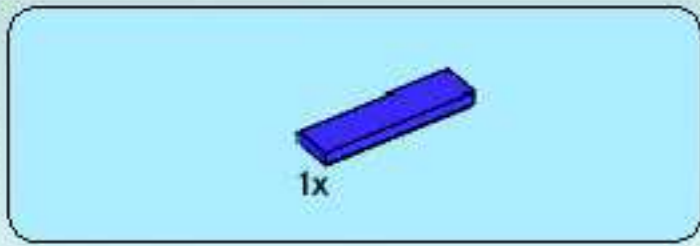

25

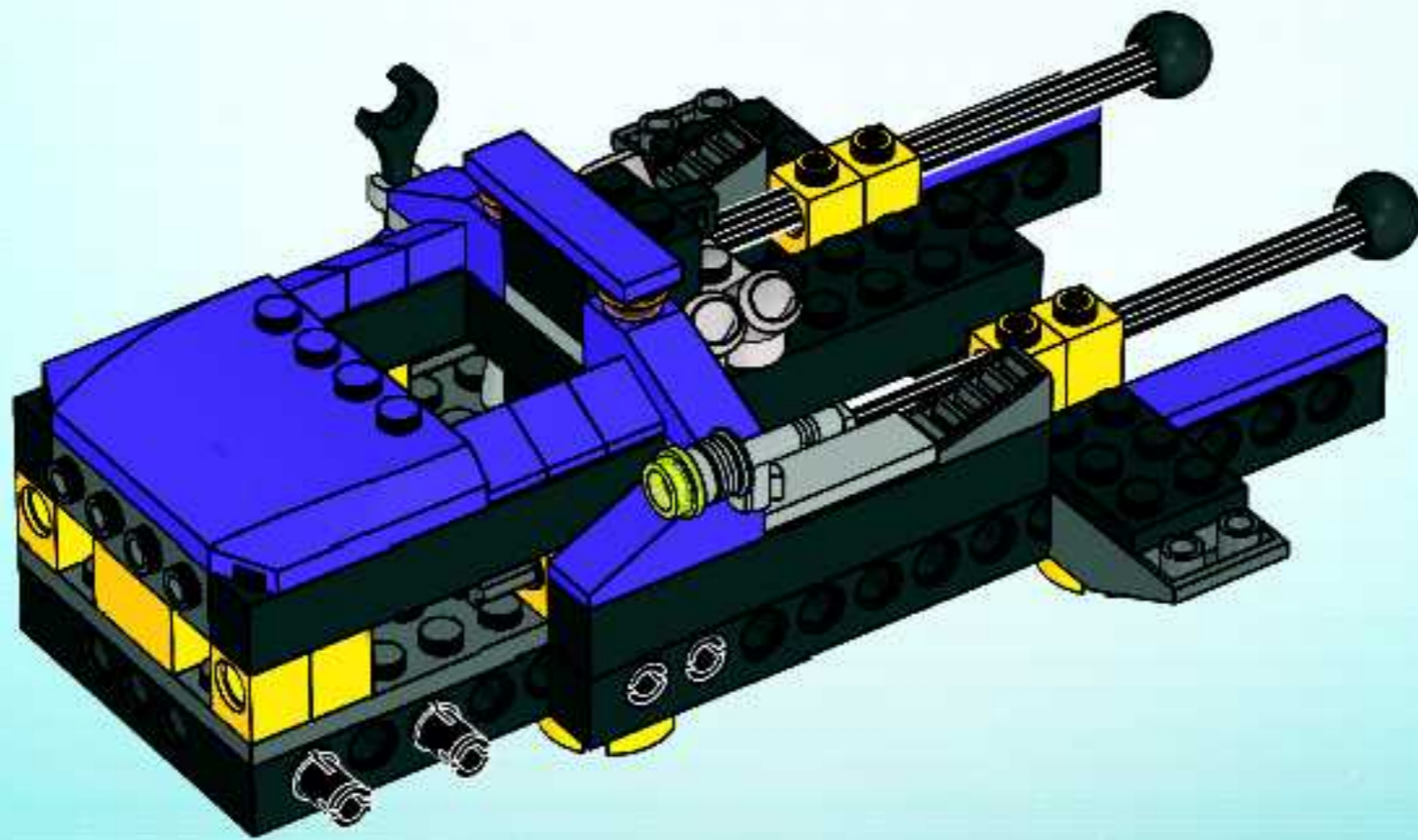



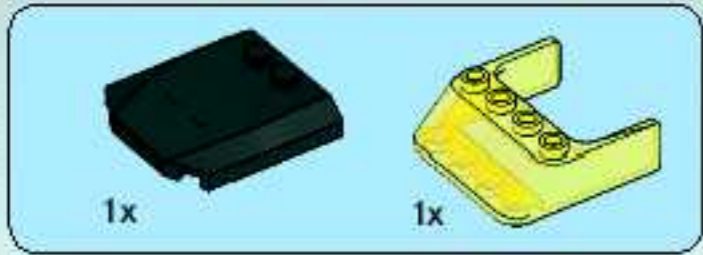

# 26

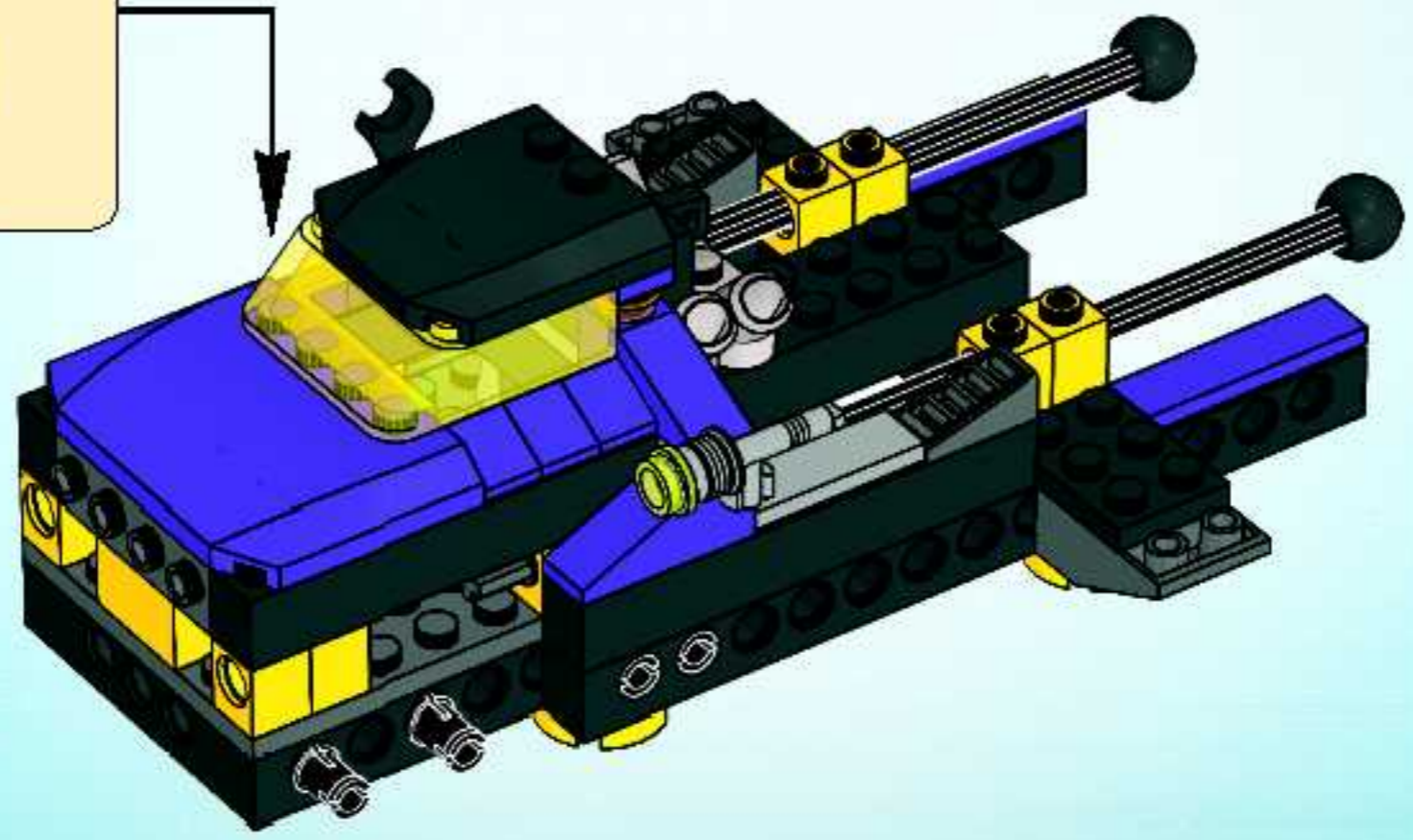
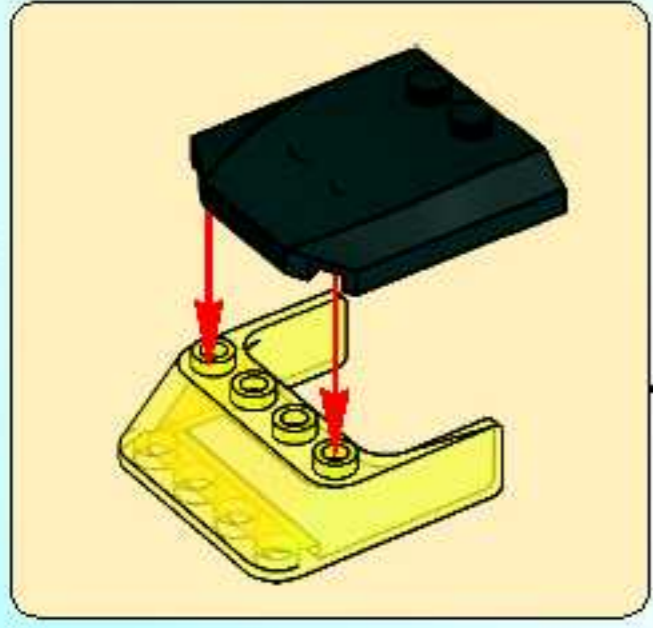



27

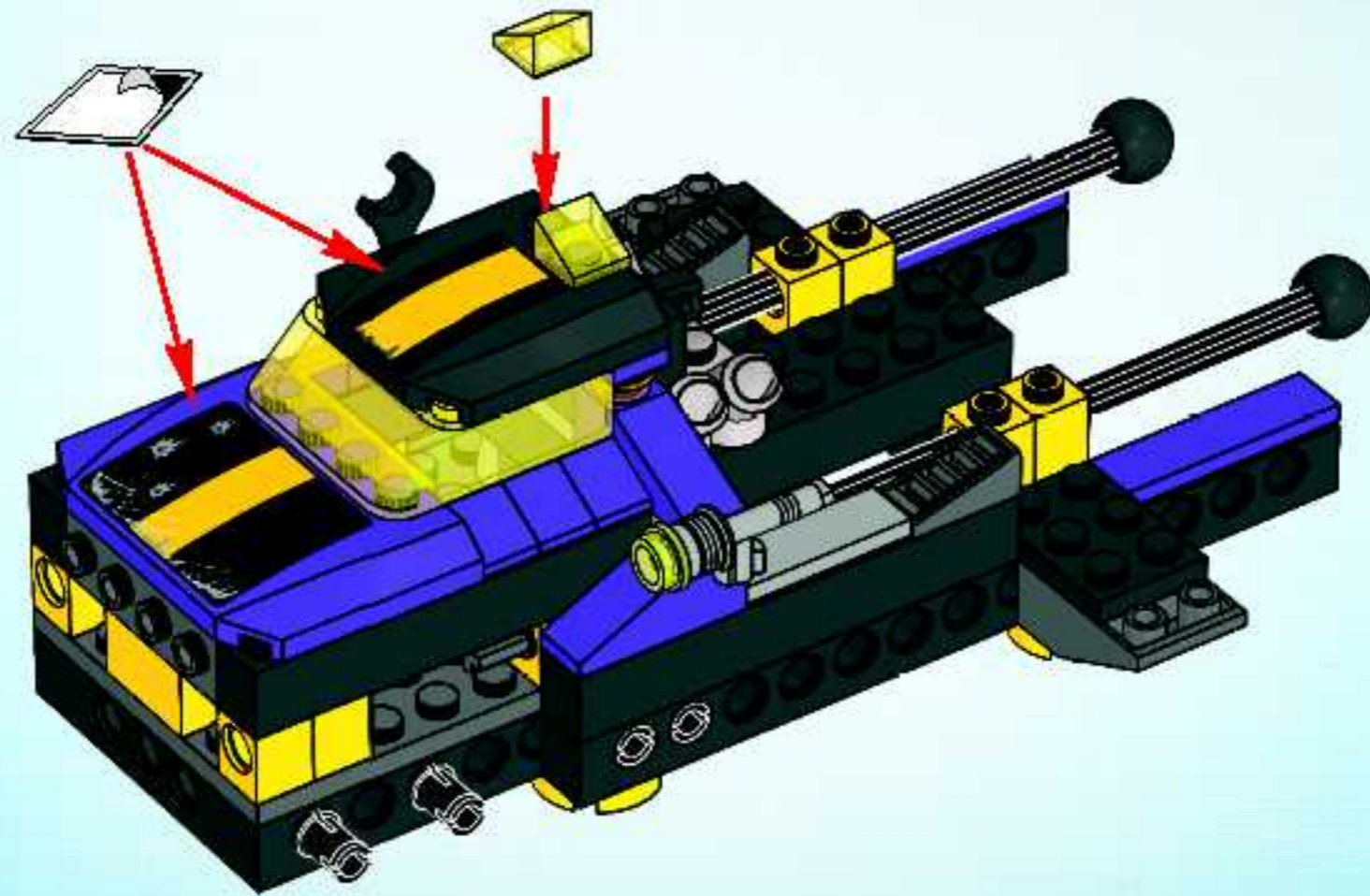

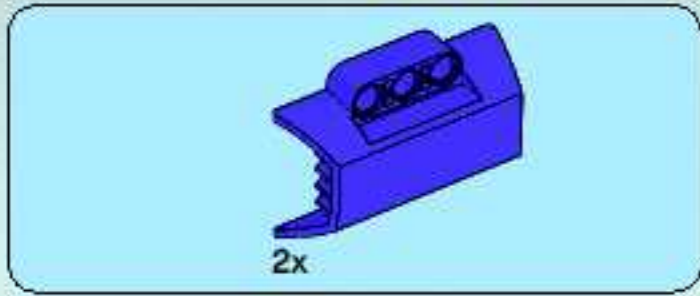

28

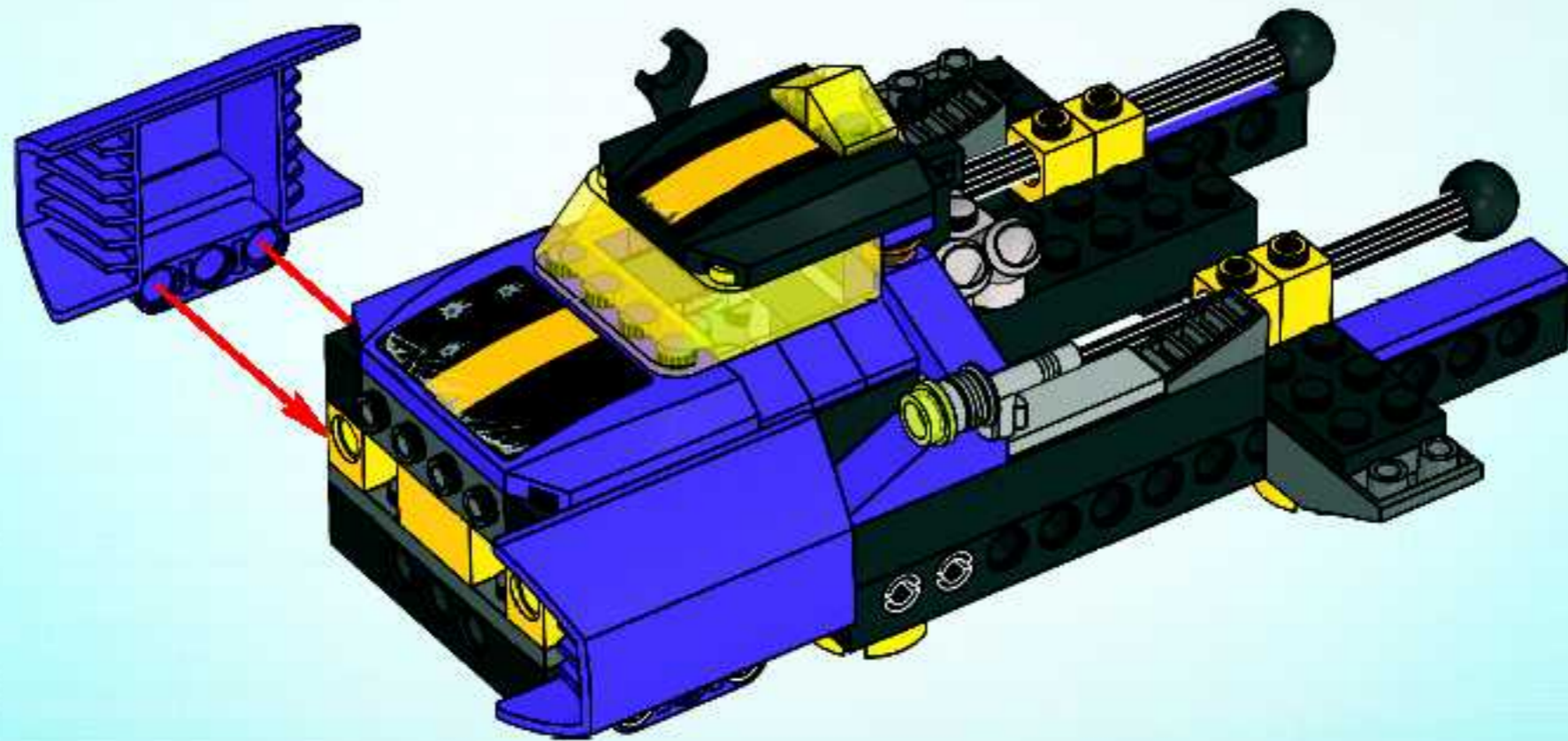

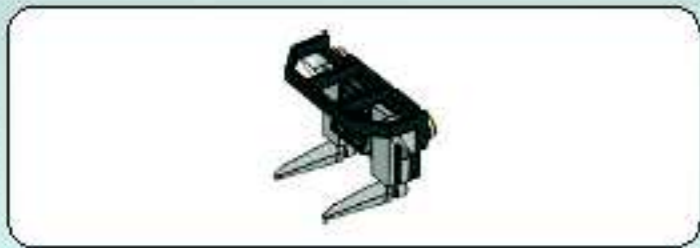

1

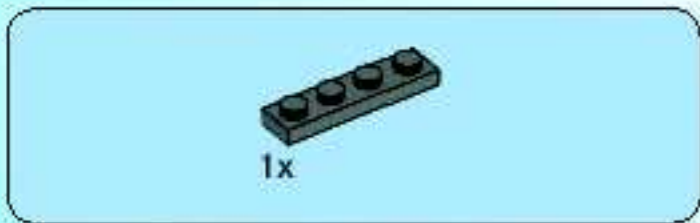
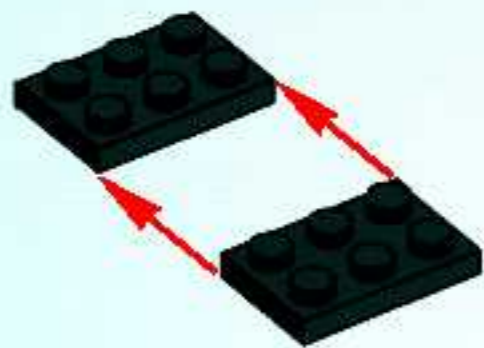

2

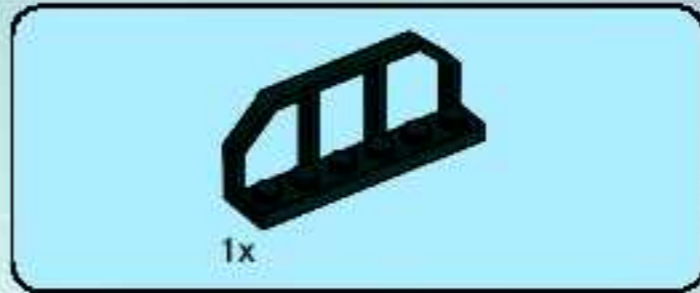

3



4

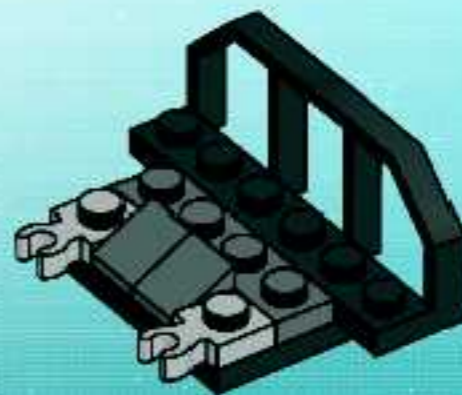

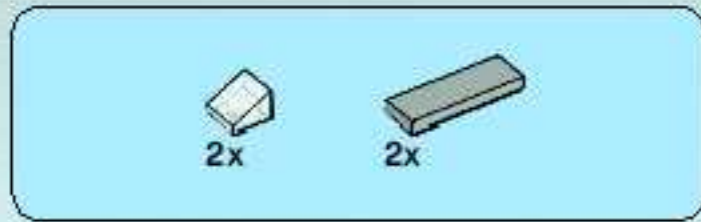

5

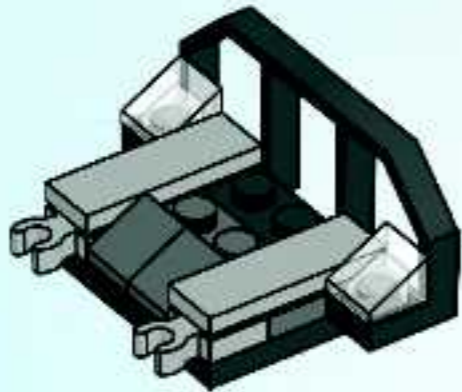

6

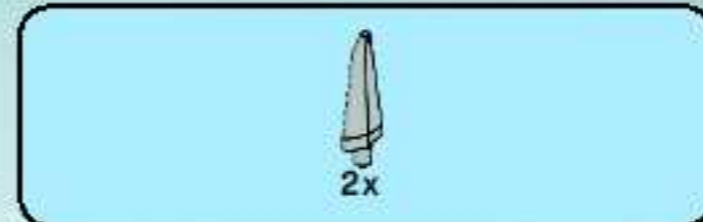
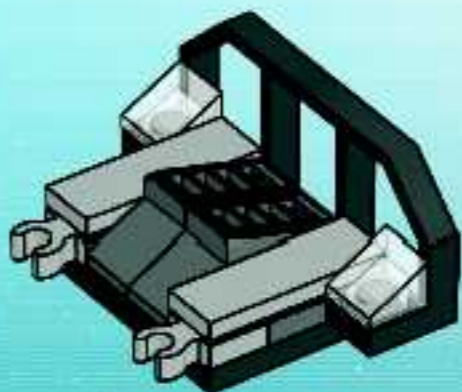

7

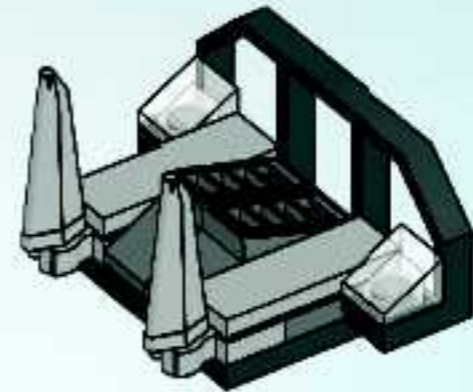

8

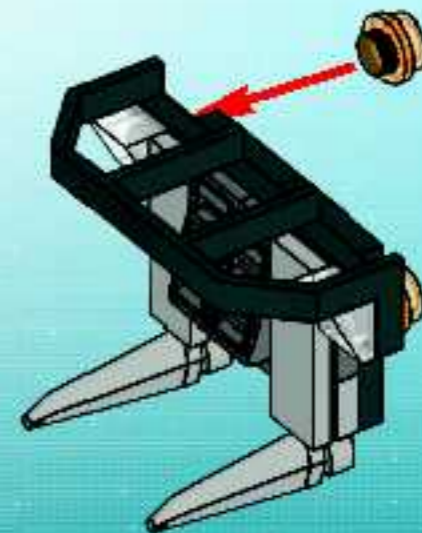

29

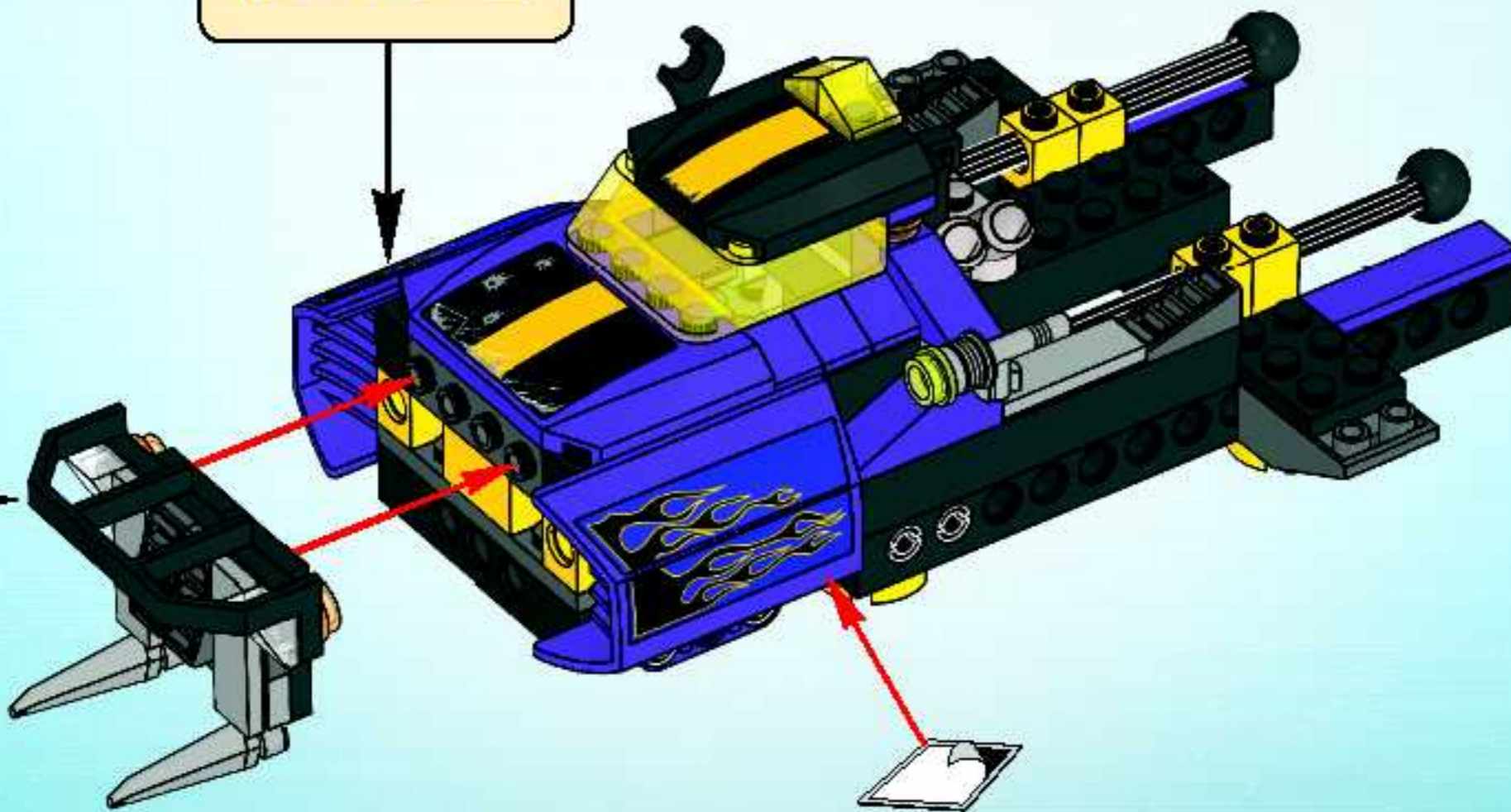
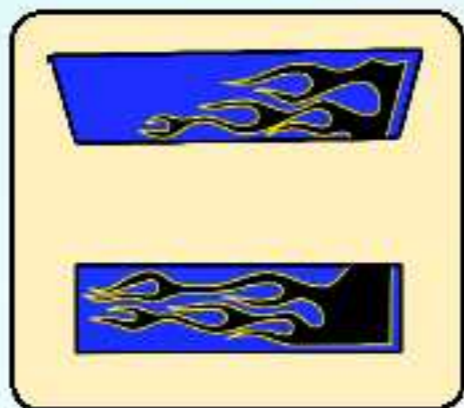



30

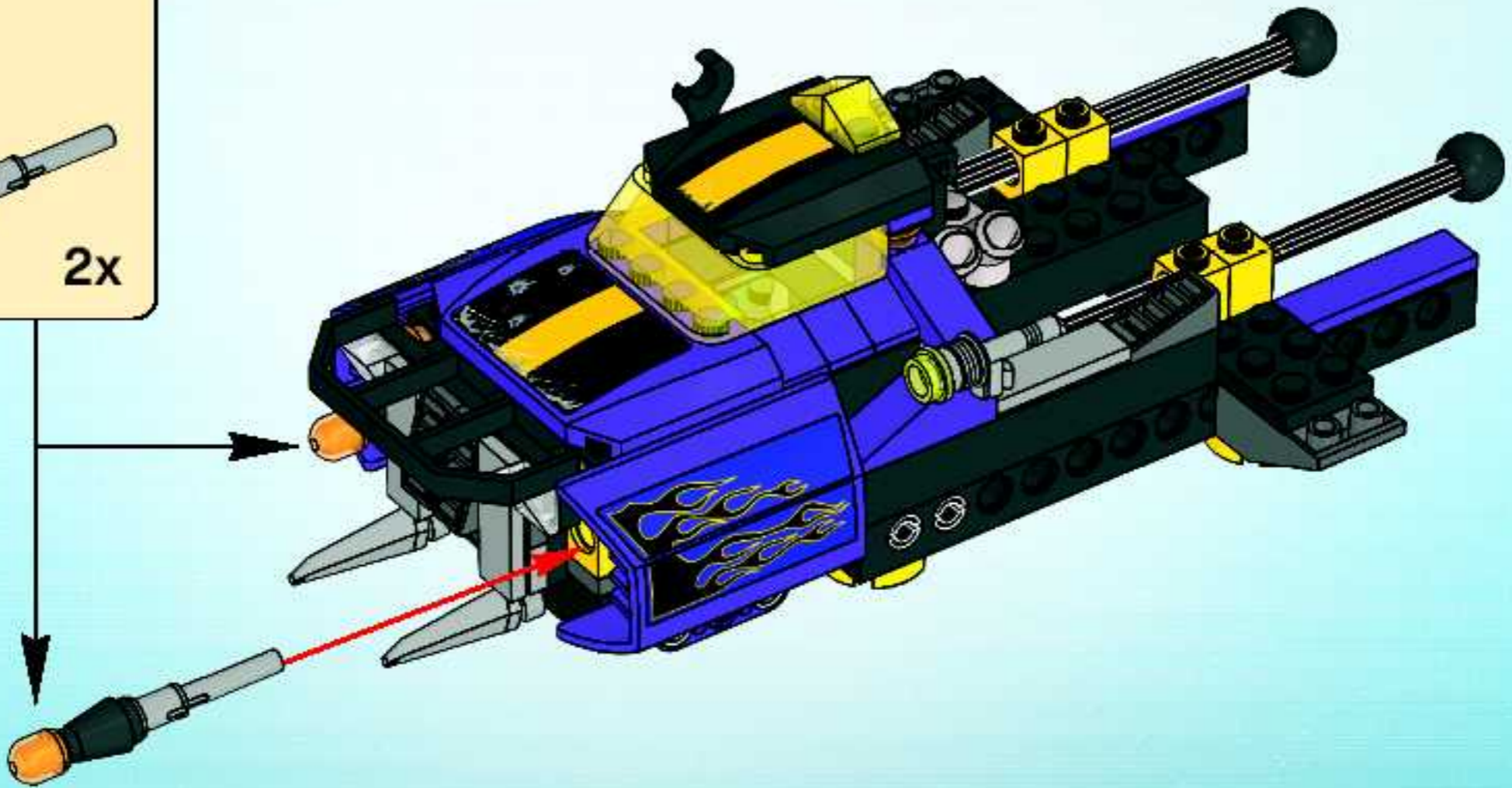
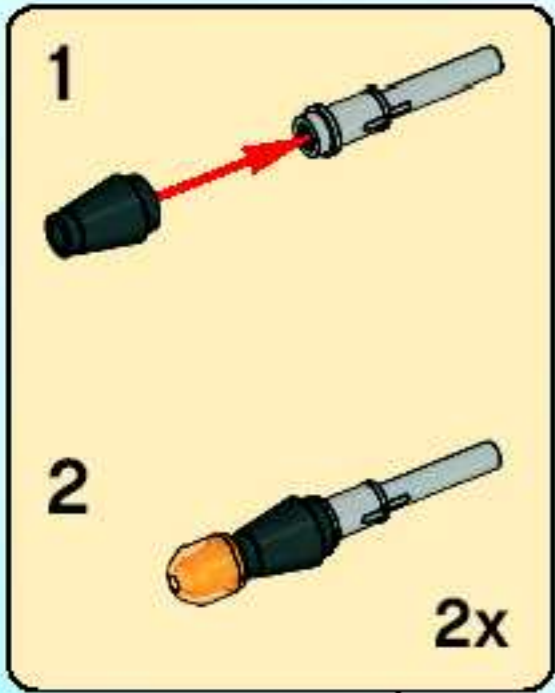



31

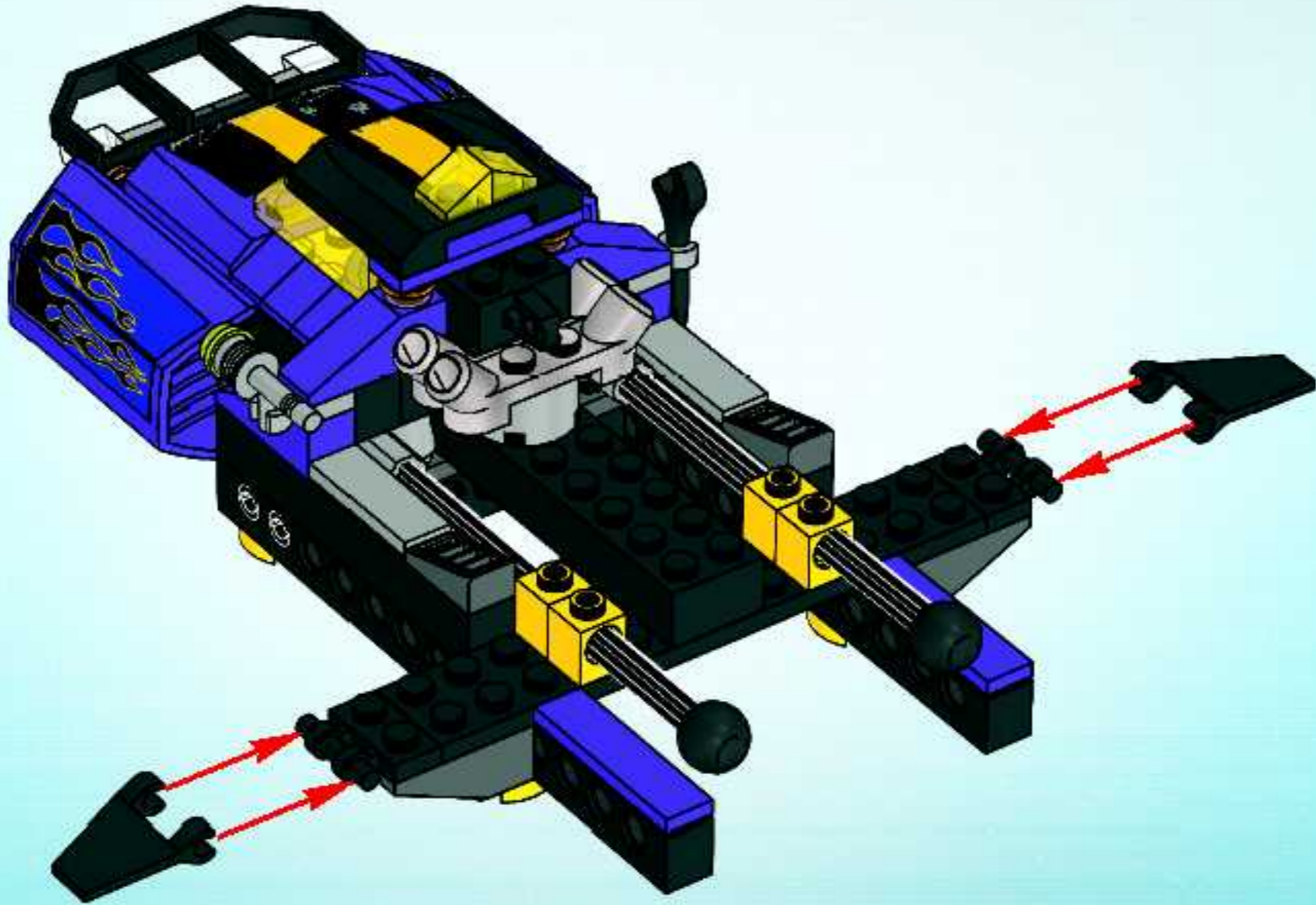



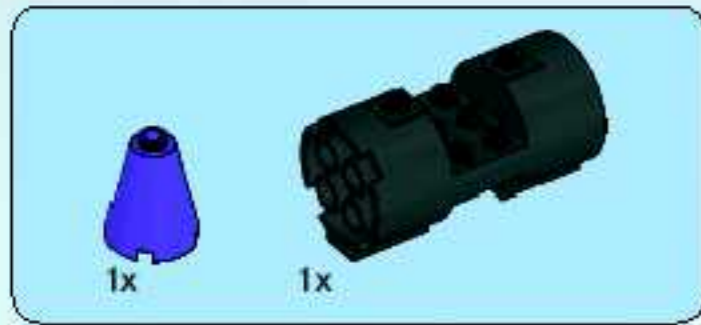

1

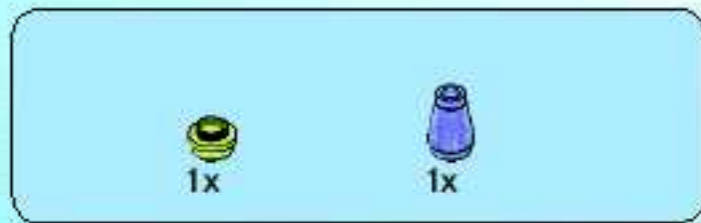
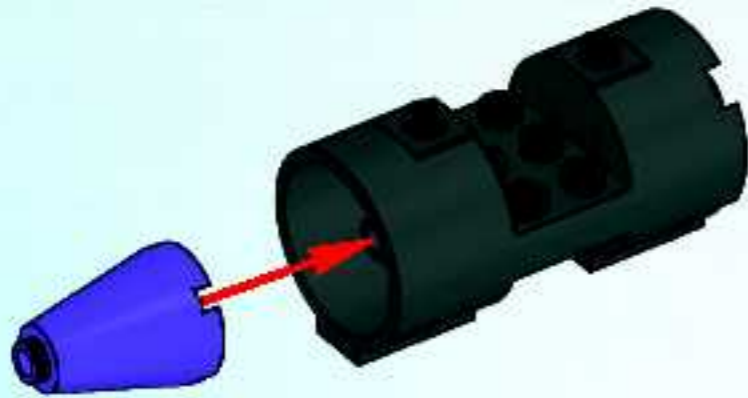

2

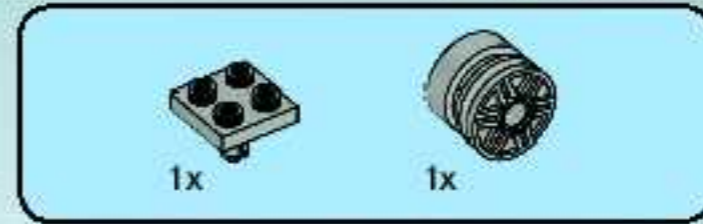
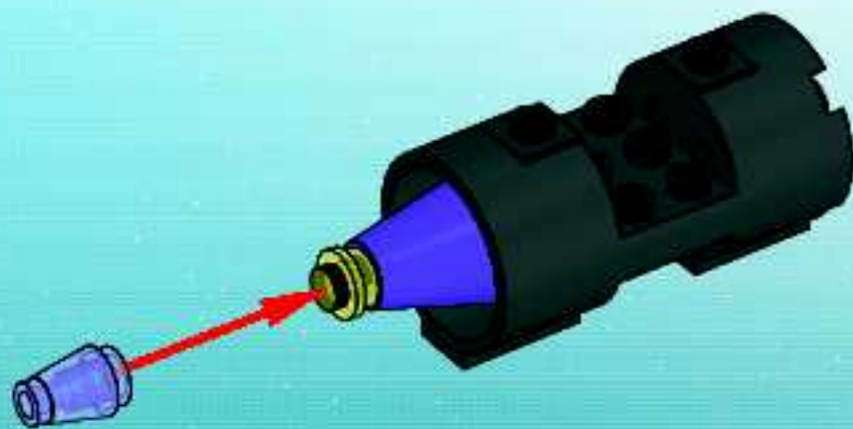

3

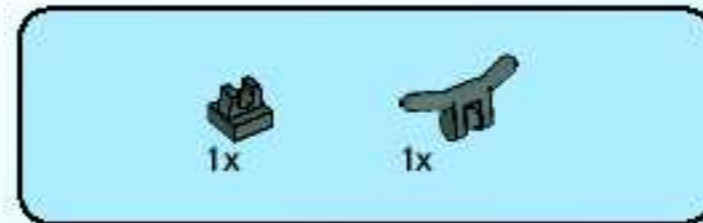
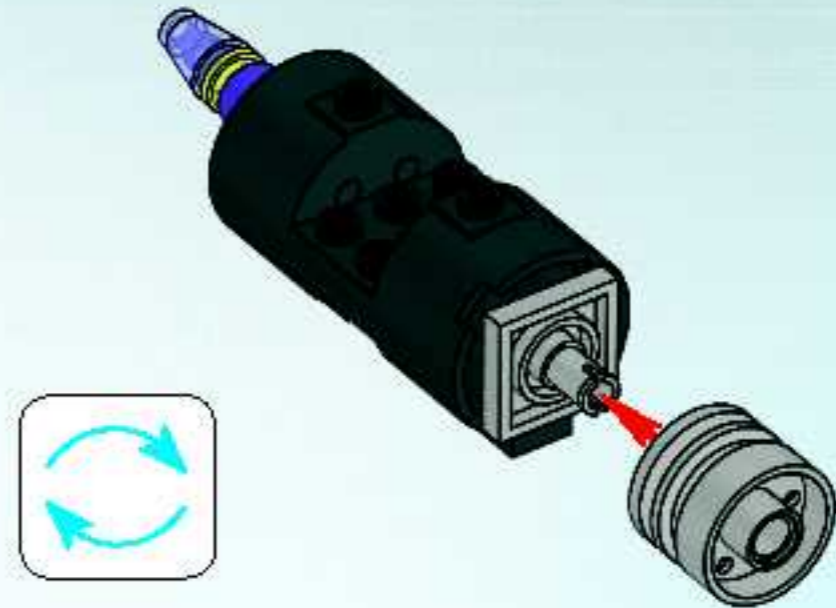

4

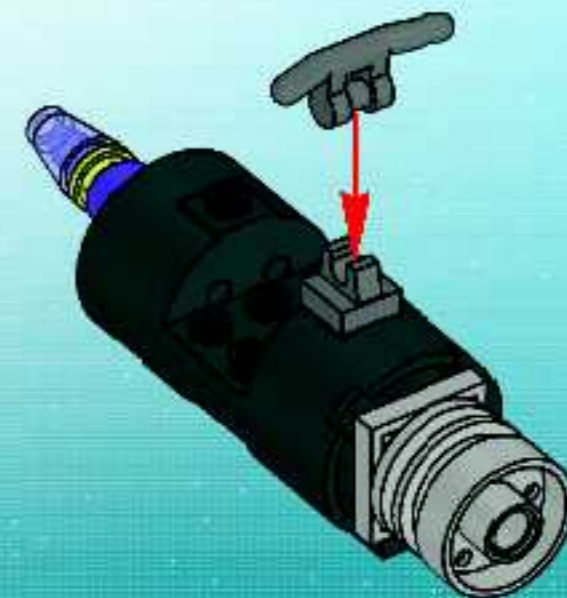

2x

32

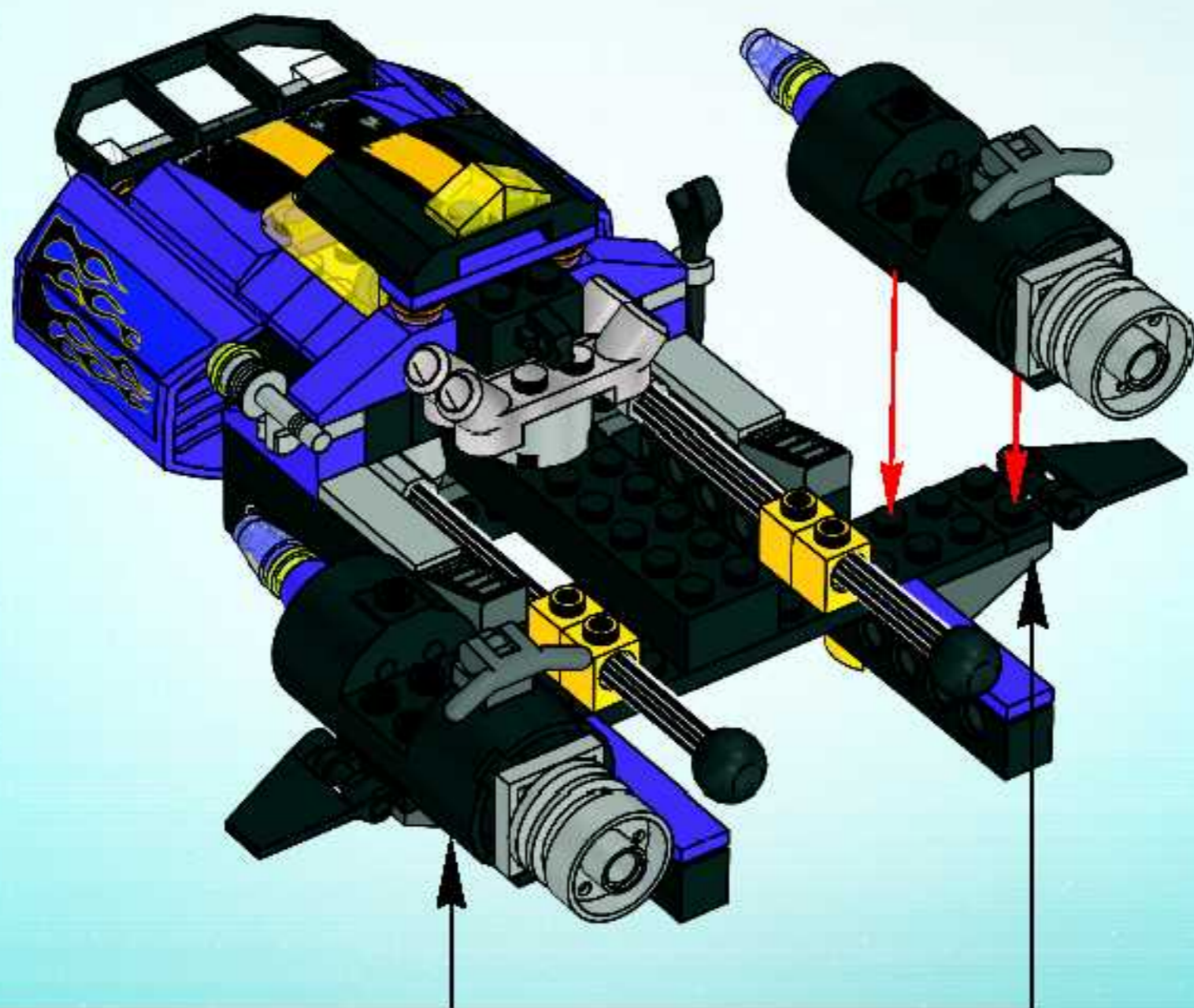



33

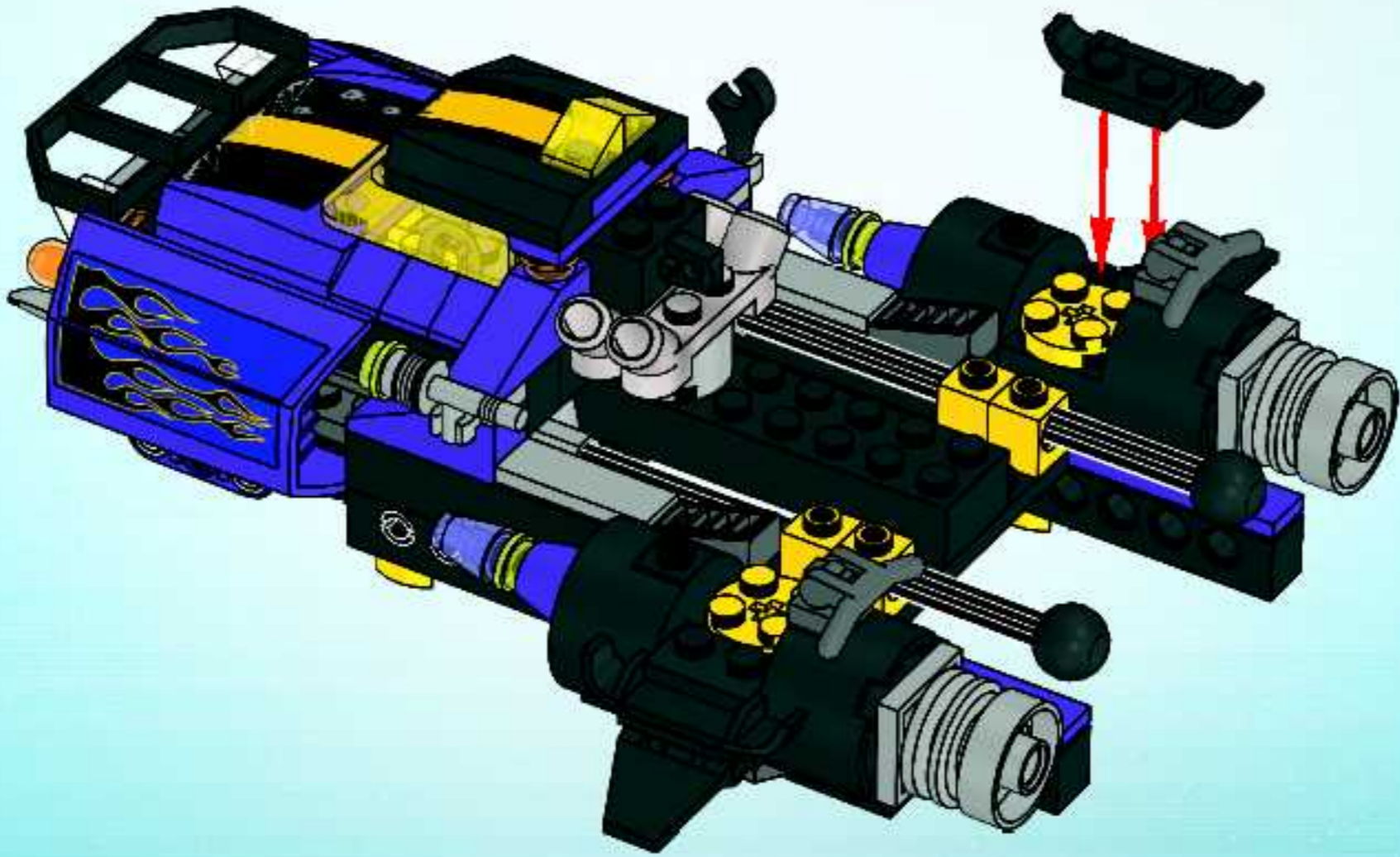



34

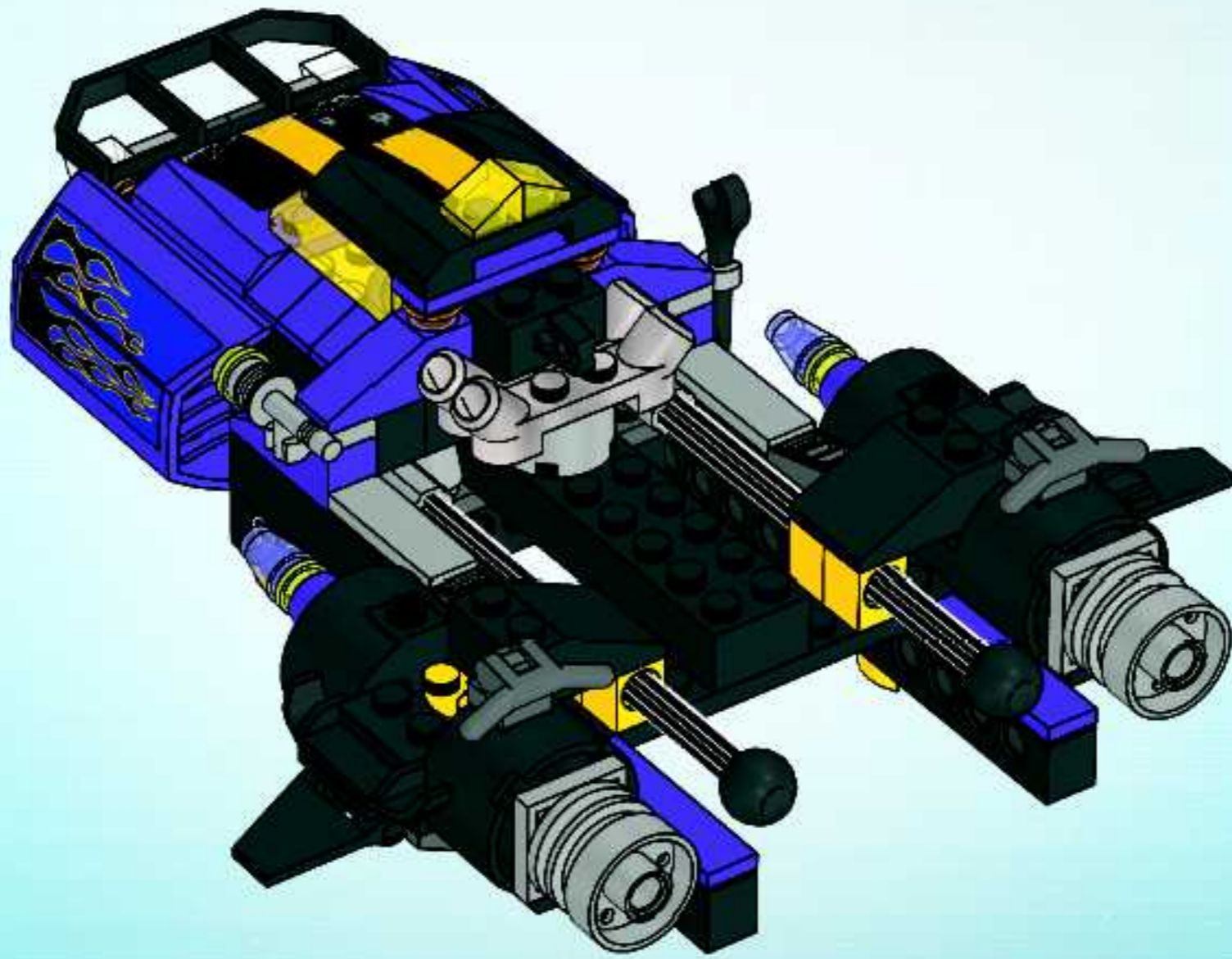

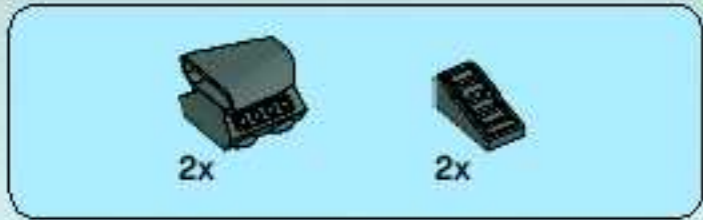

# 35

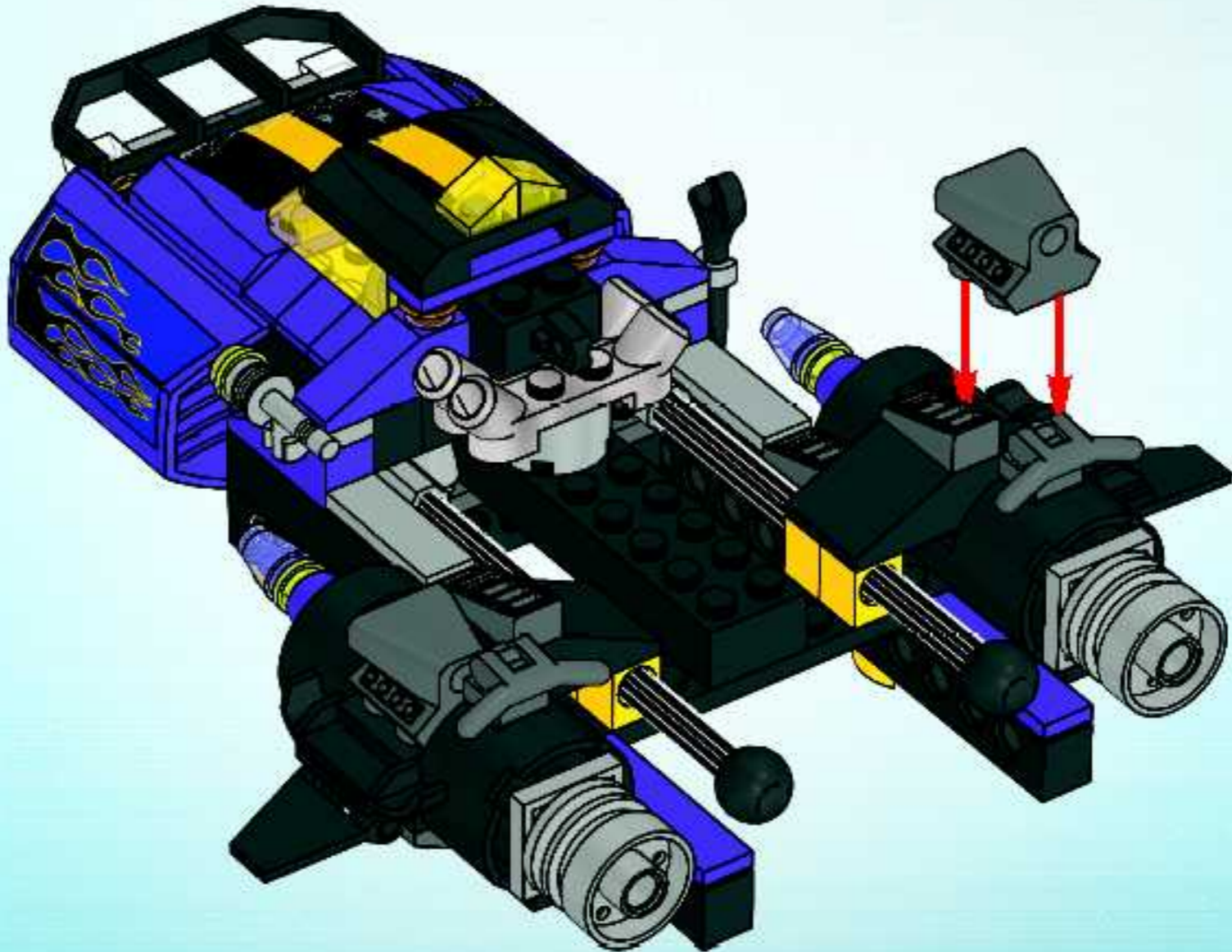

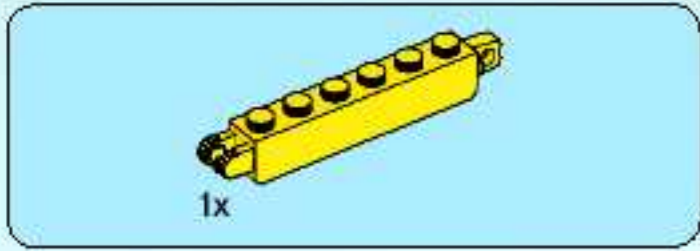

1

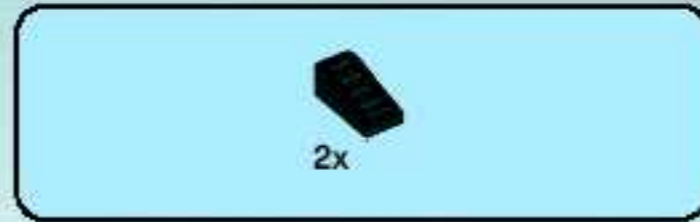
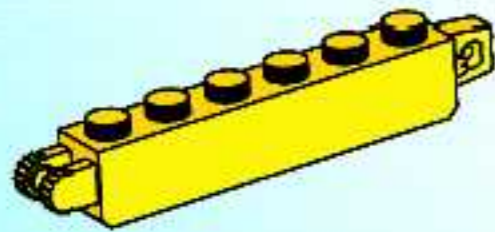

2



3

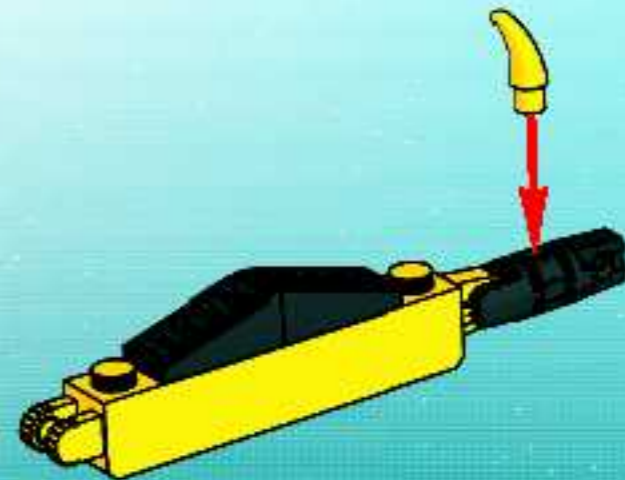



4

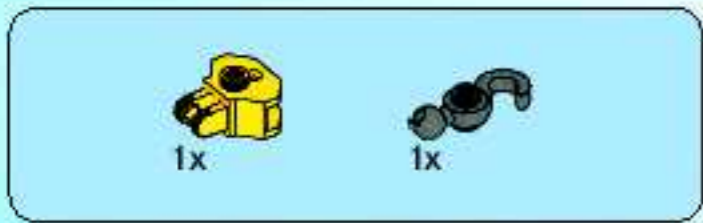
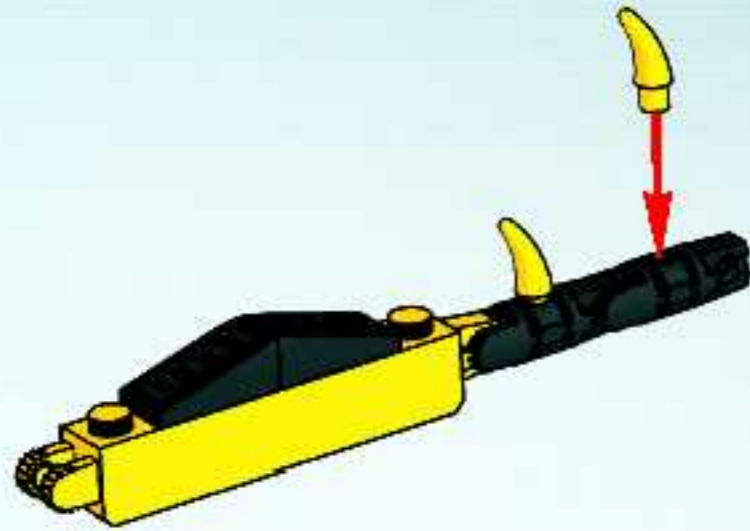

5



6



36

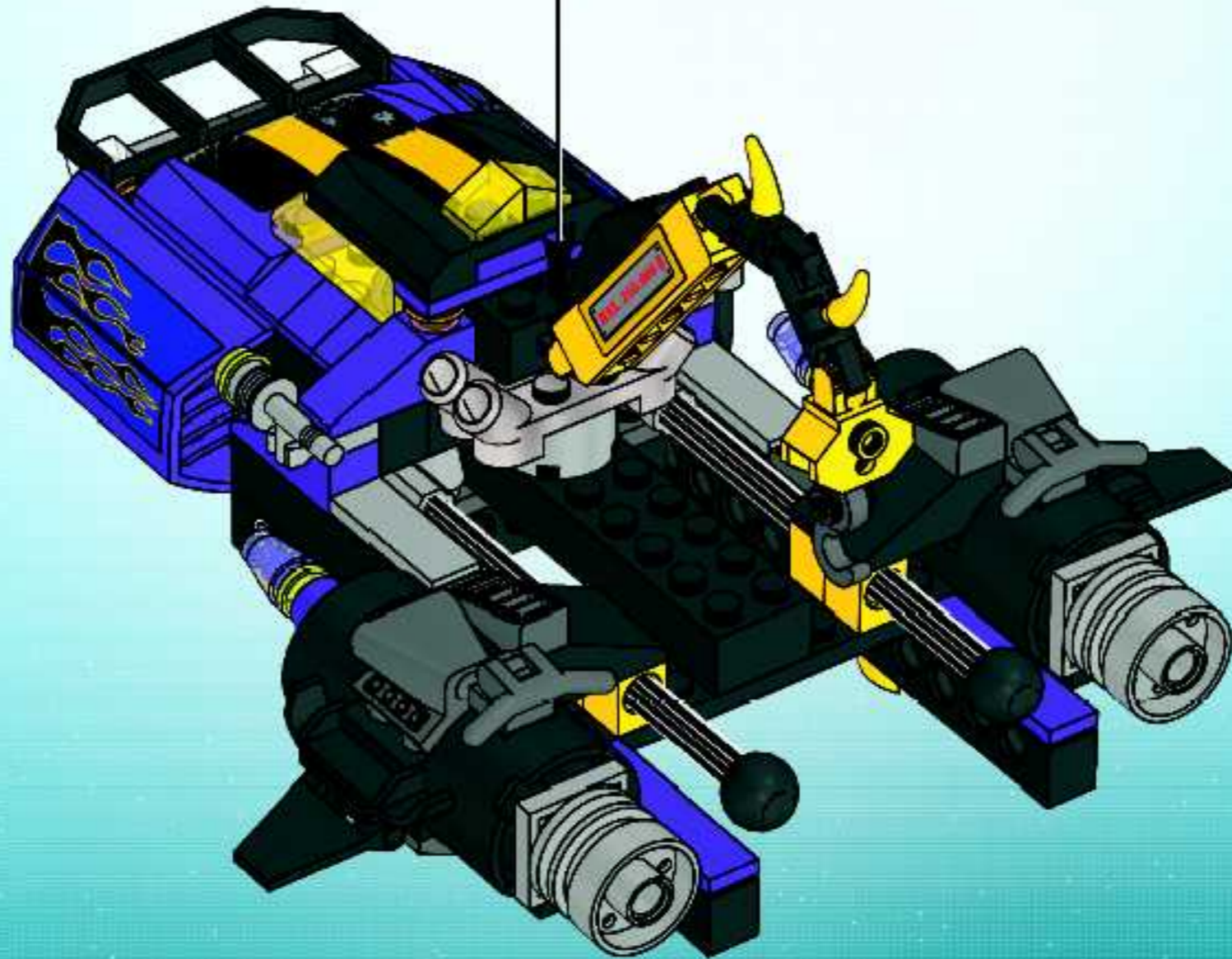





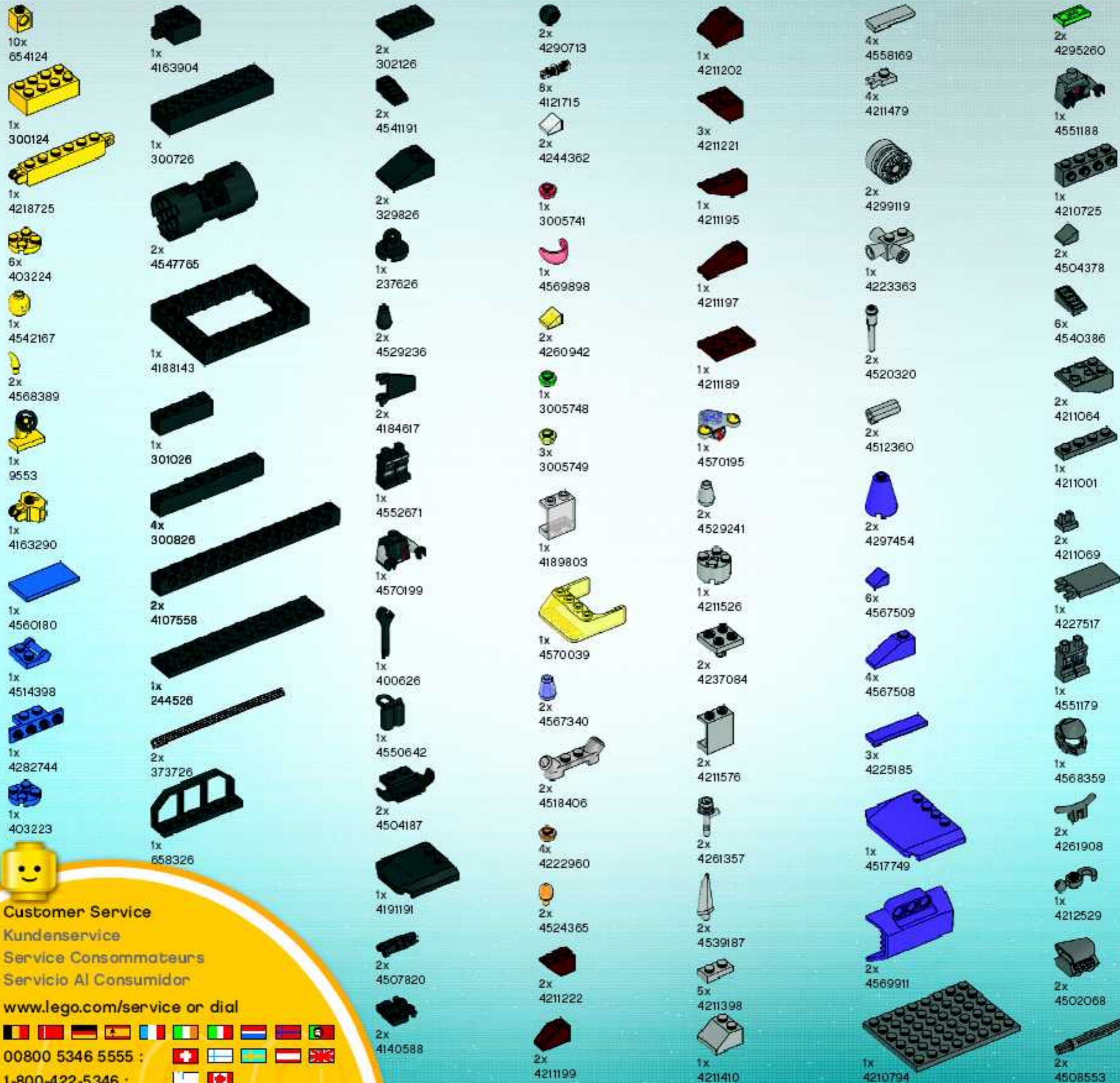

Customer Service

Kundenservice

Service Consommateurs

Servicio Al Consumidor

[www.lego.com/service](http://www.lego.com/service) or dial



00800 5346 5555 :

1-800-422-5346 :



5981



[SPACEPOLICE.LEGO.COM](http://SPACEPOLICE.LEGO.COM)







# ADVENTURES



## FIRST LEGO® DVD MOVIE! SPRING 2010

Erster LEGO® Film auf DVD! Frühling 2010 - Le premier film LEGO® en DVD! Printemps 2010 - ¡La primera película de LEGO® en DVD!  
Primavera 2010 - Primeiro Filme LEGO® em DVD! Primavera 2010 - Az első LEGO® DVD film! 2010 tavasz



LEGO and the LEGO logo are trademarks of The LEGO Group. © 2009 The LEGO Group. © 2009 TimeTown Toys. All Rights Reserved. © 2009 Universal Studios. All Rights Reserved.



FREE! GRATIS! GRATUIT!



www.LEGOclub.com



00800 5346 5555\*        

  1-866-534-6258 • 1-877-518-5346

US & Canada only

Canada seulement

\* Freephone. Mobile charges may apply. \* Numéro sans frais. Des frais peuvent s'appliquer avec les téléphones cellulaires. \* Gebührenfrei. Kosten für Anrufe aus Mobilfunknetzen können anfallen.  
\* Gratis telefonnummer vanaf vaste lijn. \* Nummer gratis wanneer u ringt vanuit vaste lijn. \* Det är gratis, när du ringer från en fasttelefon.



VISIT THE WORLD'S  
BIGGEST LEGO® SHOP!

[www.LEGOshop.com](http://www.LEGOshop.com)

**LEGO**

# SPACE POLICE

5971

5972

5969

5970



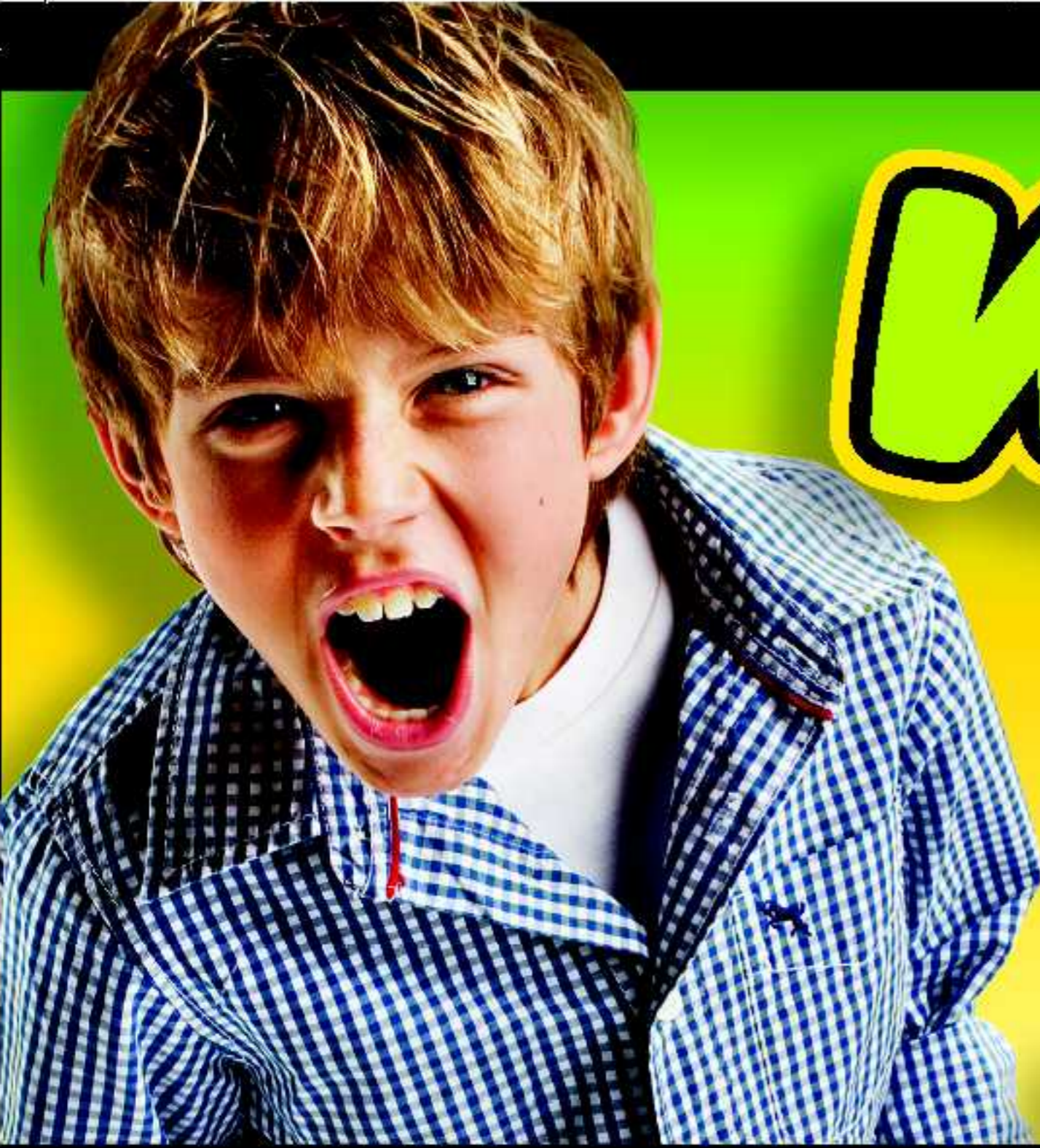

# WIN!

Go to [www.nielsen.com/LEGO](http://www.nielsen.com/LEGO) to fill out a survey for a chance to win a cool LEGO® Product. No purchase necessary. Open to all residents where not prohibited.

 [www.LEGO.com](http://www.LEGO.com)



## [www.nielsen.com/LEGO](http://www.nielsen.com/LEGO)

### GEWINNE! WIN!

Nimm an der Umfrage auf [www.nielsen.com/LEGO](http://www.nielsen.com/LEGO) teil und hab die Chance ein cooles LEGO® Produkt zu gewinnen!

Die Teilnahme am Gewinnspiel führt zu keinerlei Kaufverpflichtungen. Teilnahme in allen nicht ausgeschlossenen Ländern möglich.

Ga naar [www.nielsen.com/LEGO](http://www.nielsen.com/LEGO), vul een enquêteformulier in en maak kans op een cool LEGO® product.

Geen aankoopverplichting. Iedereen mag deelnemen, uitgezonderd ingezetenden van landen waar een enquêteverbod geldt.

### GAGNE! 当てよう!

Visite [www.nielsen.com/LEGO](http://www.nielsen.com/LEGO) pour répondre à un questionnaire et avoir une chance de gagner un produit LEGO® très cool!

Aucune obligation d'achat. Ouvert à tous les résidents des pays autorisés.

[www.nielsen.com/LEGO](http://www.nielsen.com/LEGO)にアクセスして、アンケートにご記入ください。当選者にはレゴ製品を差し上げます。

お買い上げの必要はありません。禁止されていない限り、すべての店舗にご利用いただけます。